



THE INNOVATOR OF OUR INDUSTRY®

# Nitrogen Gas Springs

*They truly are ... Better by Design*



**DESIGN-TITE**  
ISO Gas Spring (RI Series)

**DANLY**

**WARNING:**

- Use nitrogen only
- Maximum charging pressure: 150 bar (2175 psi)
- Do not weld, heat or modify gas spring
- Exhaust all pressure and depress piston before service
- Follow all installation and service instructions

**DESIGN-TITE**  
ISO Gas Spring (RI Series)

**DANLY**

**WARNING:**

- Use nitrogen only
- Maximum charging pressure: 150 bar (2175 psi)
- Do not weld, heat or modify gas spring
- Exhaust all pressure and depress piston before service
- Follow all installation and service instructions

**DESIGN-TITE**  
ISO Gas Spring (RI Series)

**DANLY**

**WARNING:**

- Use nitrogen only
- Maximum charging pressure: 150 bar (2175 psi)
- Do not weld, heat or modify gas spring
- Exhaust all pressure and depress piston before service
- Follow all installation and service instructions

**DESIGN-TITE**  
ISO Gas Spring (RI Series)

**DANLY**

**WARNING:**

- Use nitrogen only
- Maximum charging pressure: 150 bar (2175 psi)
- Do not weld, heat or modify gas spring
- Exhaust all pressure and depress piston before service
- Follow all installation and service instructions

**DESIGN-TITE**  
R.L.S. Gas Spring (RLS Series)

**DANLY**

**WARNING:**

- Use nitrogen only
- Maximum charging pressure: 150 bar (2175 psi)
- Do not weld, heat or modify gas spring
- Exhaust all pressure and depress piston before service
- Follow all installation and service instructions

**DESIGN-TITE**  
ISO Gas Spring (RI Series)

**DANLY**

**WARNING:**

- Use nitrogen only
- Maximum charging pressure: 150 bar (2175 psi)
- Do not weld, heat or modify gas spring
- Exhaust all pressure and depress piston before service
- Follow all installation and service instructions

**DESIGN-TITE**  
ISO Gas Spring (RI Series)

**DANLY**

**WARNING:**

- Use nitrogen only
- Maximum charging pressure: 150 bar (2175 psi)
- Do not weld, heat or modify gas spring
- Exhaust all pressure and depress piston before service
- Follow all installation and service instructions

## **DANLY Nitrogen Gas Springs -**

### ***Now Expanded into 9 Series***

<b>1. B and BE Series</b> <i>Extra Compact Line</i> .....	<b>page 6</b>
<b>2. C and CE Series</b> <i>Compact Line</i> .....	<b>page 16</b>
<b>3. P and PE Series</b> <i>Performance Line</i> .....	<b>page 22</b>
<b>4. S and SE Series</b> <i>North American Line</i> .....	<b>page 26</b>
<b>5. L and LE Series</b> <i>ISO Line</i> .....	<b>page 30</b>
<b>6. M Series</b> <i>Micro Line</i> .....	<b>page 36</b>
<b>7. T Series</b> <i>Super Compact Line</i> .....	<b>page 42</b>
<b>8. H Series</b> <i>Maximum Force Line</i> .....	<b>page 44</b>
<b>9. R Series</b> <i>Threaded Line</i> .....	<b>page 46</b>
 <i>Flanges</i> .....	 <b>page 50</b>
 <i>Accessories</i> .....	 <b>page 63</b>

We are proud to announce our extended and expanded range of gas springs to meet all of our customers' gas spring requirements. We now offer 9 separate series of standard pre-engineered gas springs available from stock for quick delivery.

Our expanded range includes both SinterLube® self-lubricating and conventional design gas springs, all built with the finest materials and assembled with exacting precision to provide reliability and long life in your dies.

Try DESIGN-TITE® and experience for yourself the benefits of this superior line of nitrogen products.

**They truly are...  
Better by Design.**

*DESIGN-TITE® is patented by READY Technology, Inc.*

## Design A Spring Program Order Worksheet

**Cross over worksheet for DANLY Gas Springs**  
**For FAST QUOTES ... copy this and fax DANLY the details.**

DANLY can manufacture special gas springs in as little as 3-5 days (quantity of springs and factory loading will affect delivery).

Company: \_\_\_\_\_  
 Contact Name: \_\_\_\_\_ Title: \_\_\_\_\_  
 Address: \_\_\_\_\_  
 City, County, Postcode: \_\_\_\_\_  
 Phone: \_\_\_\_\_ Fax: \_\_\_\_\_  
 Email Address: \_\_\_\_\_

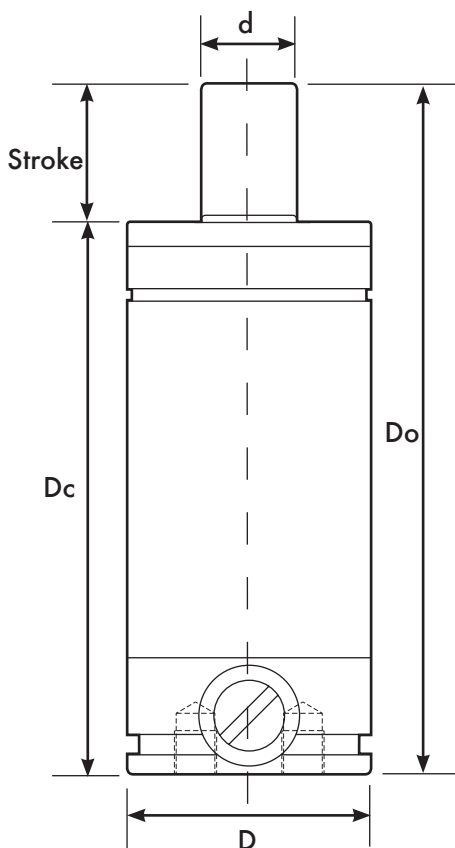

**Selection Criteria**

∅ d \_\_\_\_\_  
 ∅ D \_\_\_\_\_  
 Do \_\_\_\_\_  
 Dc \_\_\_\_\_  
 Stroke \_\_\_\_\_  
 Force Required at Do \_\_\_\_\_  
 Threaded Body  yes  no  
 Mounting Pattern \_\_\_\_\_  
 \_\_\_\_\_  
 (ex. 2x M6 on a 25 PCD)

In addition to our complete line of standard gas springs, we offer what no other gas spring manufacturer offers: a re-engineer custom gas spring manufacturing service with incomparably quick delivery.

That's right. With our "Design a Spring Program", we can special manufacture gas springs to provide an exact cross to most other gas spring models or to your application specifications.

Simply fax us a completed Design A Spring Program Order Worksheet, and Danly will promptly respond with a design solution for your requirement. We invite you to try our new and remarkable Design a Spring Program for yourself.

Experience for yourself the benefits of DESIGN-TITE® gas springs.

**They truly are...  
Better by Design.**

DANLY UK LIMITED (UK Sales Office)  
 Maybrook House, Queensway, Halesowen  
 West Midlands B63 4AH

Tel: 0121 585 7171  
 E-mail: sales@danlyuk.com

Fax: 0121 585 7272  
 website: www.danly.co.uk

**Please review the following safety information carefully.**

We have designed a number of safety features into our gas springs, but ultimately there is no substitute for caution and good shop practice.

Gas springs are tools containing nitrogen gas under high pressure. It is imperative to follow all warnings and recommendations. Any unauthorized use may result in serious injury and/or damage to tooling.



All gas springs use Nitrogen gas (N<sub>2</sub>) only! No other medium will be used.



When handling all gas springs please use care! Any damage or imperfections may result in affecting the performance or life of the gas spring. Should any gas spring become damaged, please discharge before performing any repairs.



Always secure gas springs before transporting or storing.



Any alterations (drilling, machining...) to the gas spring is prohibited.

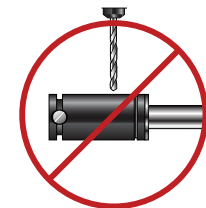

Use the correct device to check gas spring force. Gas springs should not be improperly compressed to check force.

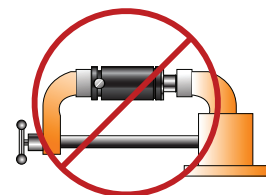

Avoid sudden release of gas spring piston.

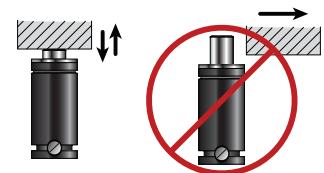

Danly strongly recommends all gas springs stay within 90% of total stroke; this will improve spring life and safety. Not following this recommendation may result in damage of spring or possible explosion from over-stroking.

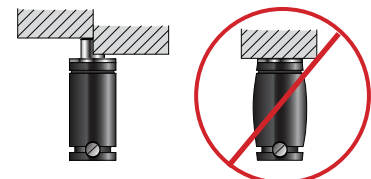

Before repairing any gas spring you must exhaust gas completely. Push piston into body of gas spring to be safe. Before discarding a worn gas spring you must discharge completely and push piston fully into gas spring body.

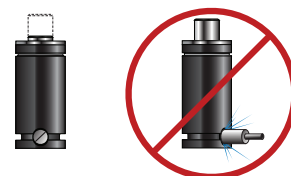

When discharging gas spring it's recommended the discharge point should be placed upward. Protective goggles must be worn during this operation.



Do not charge gas spring unless the piston is fully extended. Briefly inspect the gas spring after pre-charging 5-10 bar, then charge to the required pressure between the maximum and minimum specified.

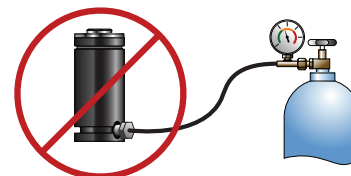

Before discarding a worn gas spring you must discharge completely and push piston fully into gas spring body.

*When gas spring repair is required, Danly recommends using trained, authorized personnel. Should there be any questions regarding maintenance of gas springs please contact our Technical Department.*

## Installation Guidelines

Mounting surface under gas springs should be flat. Inadequate mounting surfaces will damage or reduce the life of the gas springs.

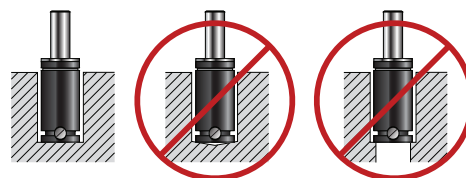

Mounting the gas spring to a surface using the tapped holes in the base of the gas spring is ideal. At no time should you use the tapped hole in the piston for mounting. Make sure the length of the screws is such that the base of the gas spring sits flat against the surface.

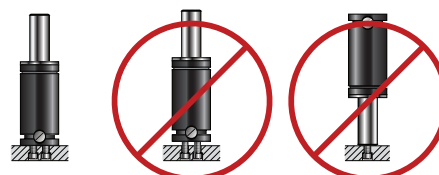

Danly offers a wide range of mounting options using our variety of flanges.

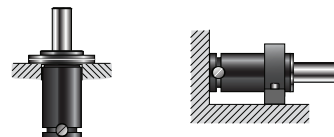

Gas springs must always be perpendicular to the working surface, any deviation, whether it's angular or square, will affect the life of the spring.



Try to avoid contaminants and/or particles from making direct contact with the gas springs. When mounting gas spring into an enclosed area or pocket, be sure to clean area regularly or have a drainage hole.

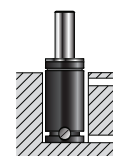

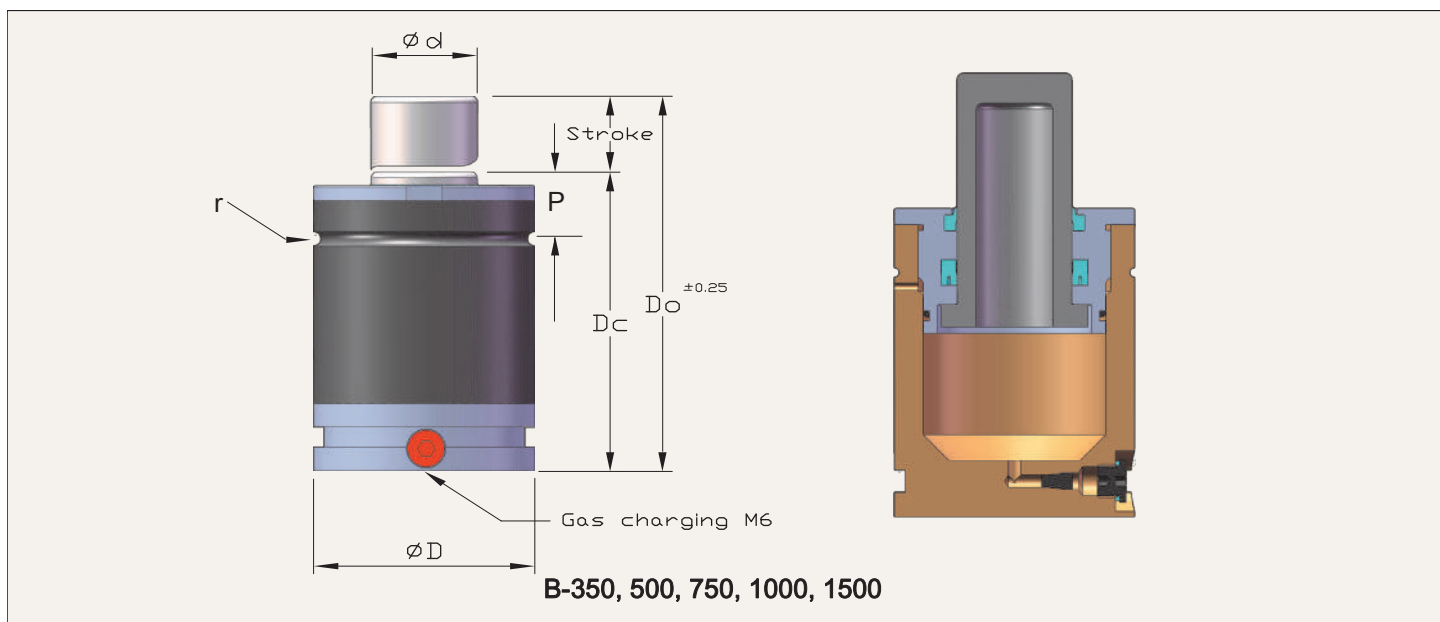

### Important!

Pressure medium: **Nitrogen Gas (N<sub>2</sub>)**  
 Operating temperature: **0 to +80°C**  
 Force increase by temperature: **0,33% / °C**

### The Extra Compact Line (B series)

Every DESIGN-TITE® Extra Compact gas spring combines the convenience of a self-contained gas spring with increased on-contact force and shorter body height.

### SinterLube® Top Cap

- Solid steel top cap with revolutionary SinterLube® lining.
- Designed with greater bearing area for improved support and guiding (A)
- Threaded construction creates greater structural strength and safety.

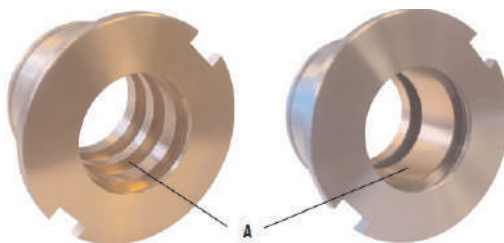





SinterLube® is a proprietary alloy material having good sliding lubricity and hardness which we have successfully used for years in guide bushings. We have now adapted this same technology to manufacturing a new line of top caps for our B series of nitrogen gas springs.

Part N°	Max. stem speed m/s	Max. charging pressure (bar)	Min. charging pressure (bar)	Order No for spare parts kit
B-350	1.0	180	50	B-350-SK
B-500	1.0	150	50	B-500-SK
B-750	0.8	150	50	B-750-SK
B-1000	0.8	150	50	B-1000-SK
B-1500	1.0	150	50	B-1500-SK

Part N°															
B-350	✓	✓	DS 32	DP 32	—	—	—	—	—	—	—	—	—	—	
B-500	✓	✓	DS / DSC 38	DP 38	—	—	—	—	—	—	—	—	—	—	
B-750	✓	✓	DS / DSC 45	DP 45	DB 45	DI 45	—	—	—	—	—	—	—	—	
B-1000	✓	✓	DS / DSC 50	DP 50	DB 50	DI 50	—	—	—	—	—	—	—	—	
B-1500	✓	✓	DS / DSC 63	DP 63	DB 63	—	—	—	—	—	—	—	—	—	

Flange Details: See pages 50-56

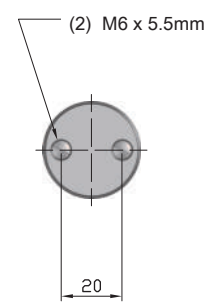
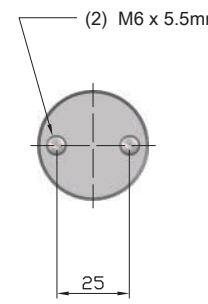
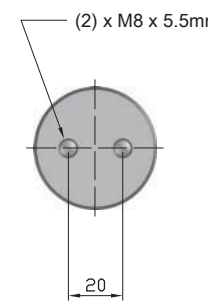
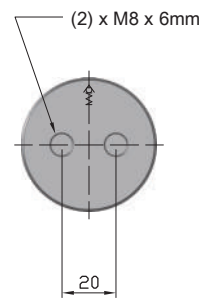
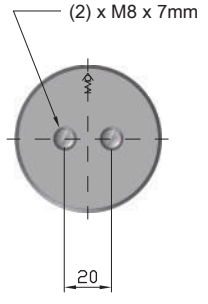

Part N° Model x stroke (mm)	Do mm	Dc mm	ØD mm	Ød mm	P mm	r mm	 bar	 daN	 daN	 Kg		Cylinders								
<b>B-350 x 10</b>	50	40	32	16	12.5	1	180	362	586	.21	—									
13	56	43							598	.22										
16	62	46							606	.23										
19	68	49							612	.24										
25	80	55							620	.26										
32	94	62							626	.29										
38	106	68							629	.31										
50	130	80							637	.35										
63	156	93							652	.40										
75	180	105							662	.44										
80	190	110							666	.46										
100	230	130							677	.54										
125	280	155							686	.64										
<b>B-500 x 10</b>	50	40							38	20			12.5	1	150	470	779	.30	—	
13	56	43	801	.31																
16	62	46	817	.33																
19	68	49	828	.34																
25	80	55	844	.37																
32	94	62	856	.40																
38	106	68	863	.43																
50	130	80	872	.49																
63	156	93	881	.55																
75	180	105	900	.62																
80	190	110	907	.65																
100	230	130	927	.76																
125	280	155	946	.90																
<b>B-750 x 10</b>	52	42	45	25	15.5	1	150	736			1286	.44					—			
13	58	45							1300	.46										
16	64	48							1325	.48										
19	70	51							1344	.50										
25	82	57							1370	.54										
32	96	64							1389	.58										
38	108	70							1400	.62										
50	132	82							1415	.70										
63	158	95							1425	.78										
75	182	107							1452	.87										
80	192	112							1468	.92										
100	232	132							1518	.108										
125	282	157							1563	1.29										
<b>B-1000 x 13</b>	64	51							50	28	15.5	2	150	925	1543	.65			—	
16	70	54	1585	.67																
19	76	57	1617	.69																
25	88	63	1662	.74																
32	102	70	1697	.80																
38	114	76	1718	.84																
50	138	88	1747	.94																
63	164	101	1767	1.04																
75	188	113	1815	1.16																
80	198	118	1837	1.21																
100	238	138	1910	1.42																
125	288	163	1978	1.68																
<b>B-1500 x 13</b>	70	57	63	36	19	2	150	1527							2411	1.14	—			
16	76	60													2493	1.17				
19	82	63							2558	1.21										
25	94	69							2655	1.29										
32	108	76							2733	1.38										
38	120	82							2783	1.45										
50	144	94							2852	1.61										
63	170	107							2902	1.77										
75	194	119							2934	1.92										
80	204	124							2945	1.99										
100	244	144							3059	2.31										
125	294	169							3207	2.74										

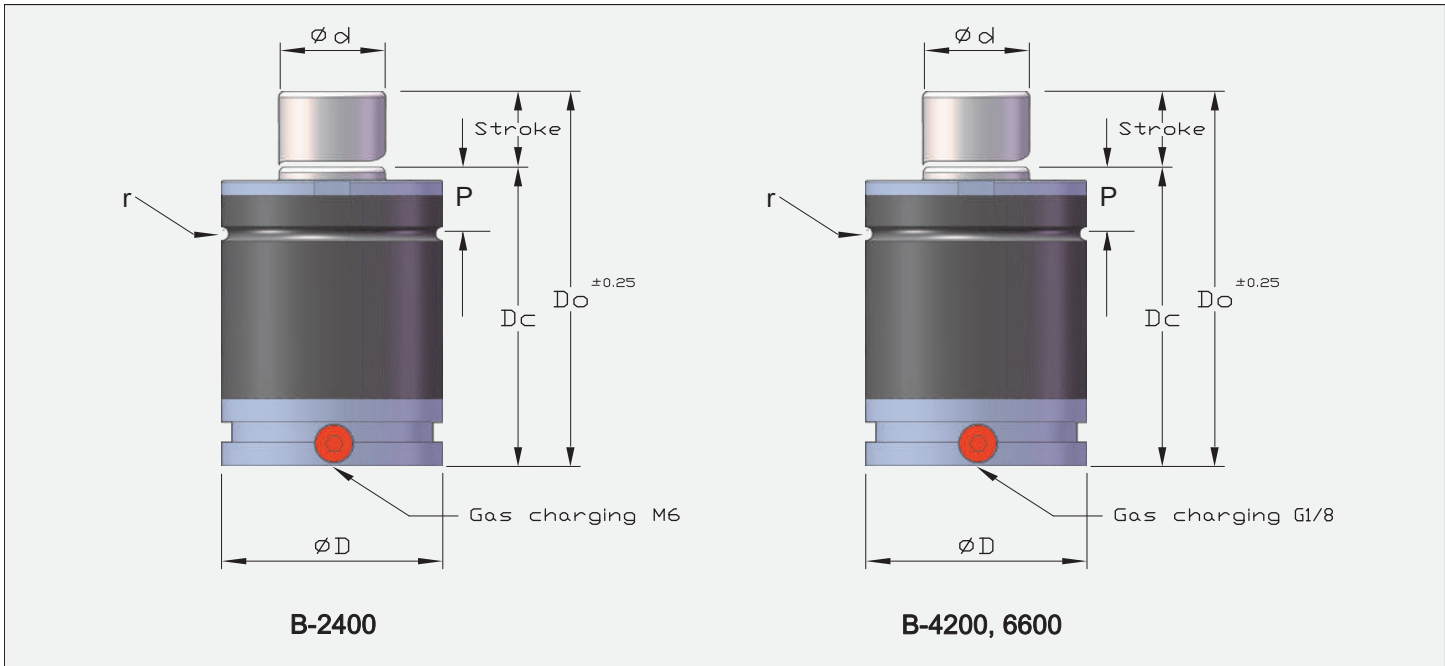

**Important!**

Pressure medium: **Nitrogen Gas (N<sub>2</sub>)**  
 Operating temperature: **0 to +80°C**  
 Force increase by temperature: **0,33% / °C**

**The Extra Compact Line (B series)**

Every DESIGN-TITE® Extra Compact gas spring combines the convenience of a self-contained gas spring with increased on-contact force and shorter body height.

**SinterLube® Top Cap**

- Solid steel top cap with revolutionary SinterLube® lining.
- Designed with greater bearing area for improved support and guiding (A)
- Threaded construction creates greater structural strength and safety.

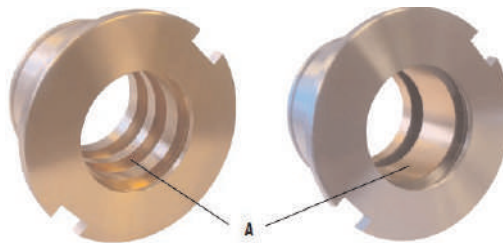

SinterLube® is a proprietary alloy material having good sliding lubricity and hardness which we have successfully used for years in guide bushings. We have now adapted this same technology to manufacturing a new line of top caps for our B series of nitrogen gas springs.

Part N°	Max. stem speed m/s	Max. charging pressure (bar)	Min. charging pressure (bar)	Order No for spare parts kit
B-2400	1.0	150	50	B-2400-SK
B-4200	1.0	150	50	B-4200-SK
B-6600	0.6	150	50	B-6600-SK

Part N°						
B-2400	✓	✓	DS / DSC 75	DP 75	DB 75	DI 75
B-4200	✓	✓	DS / DSC 95	DP 95	DB 95	DI 95
B-6600	✓	✓	DS / DSC 120	DP 120	DB 120	DI 120

Flange Details: See pages 50-56





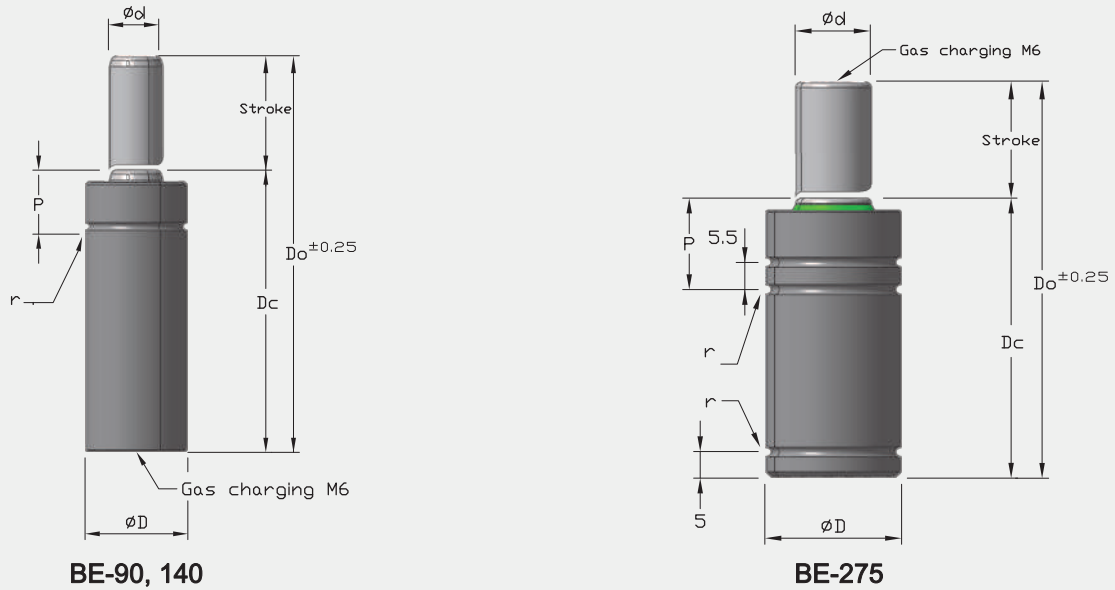

**BE-90, 140**

**BE-275**

**Important!**

Pressure medium: **Nitrogen Gas (N<sub>2</sub>)**  
 Operating temperature: **0 to +80°C**  
 Force increase by temperature: **0,33% / °C**

**The Extra Compact Line (BE series)**

Every Extra Compact gas spring combines the convenience of a self-contained gas spring with increased on-contact force and shorter body height.

**MODEL COMPARISON - BODY DIAMETER 50mm - STROKE 25mm**

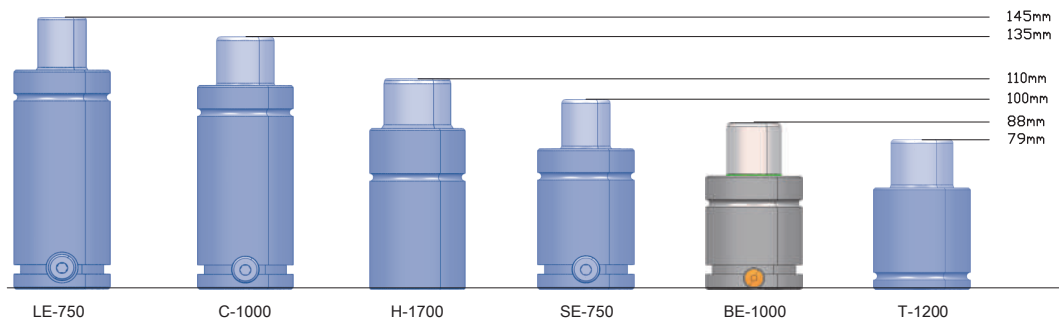

Part N°	Max. stem speed m/s	Max. charging pressure (bar)	Min. charging pressure (bar)	Order No for spare parts kit
BE-90	0.5	175	50	Kit BE-00090
BE-140	0.5	175	25	Kit BE-00140
BE-275	0.5	175	50	Kit BE-00275

Part N°						
BE-90	✓	✓	—	—	—	—
BE-140	✓	✓	DS 19	—	—	—
BE-275	✓	✓	DS / DSC 25	—	—	—

**Flange Details:** See pages 50-56



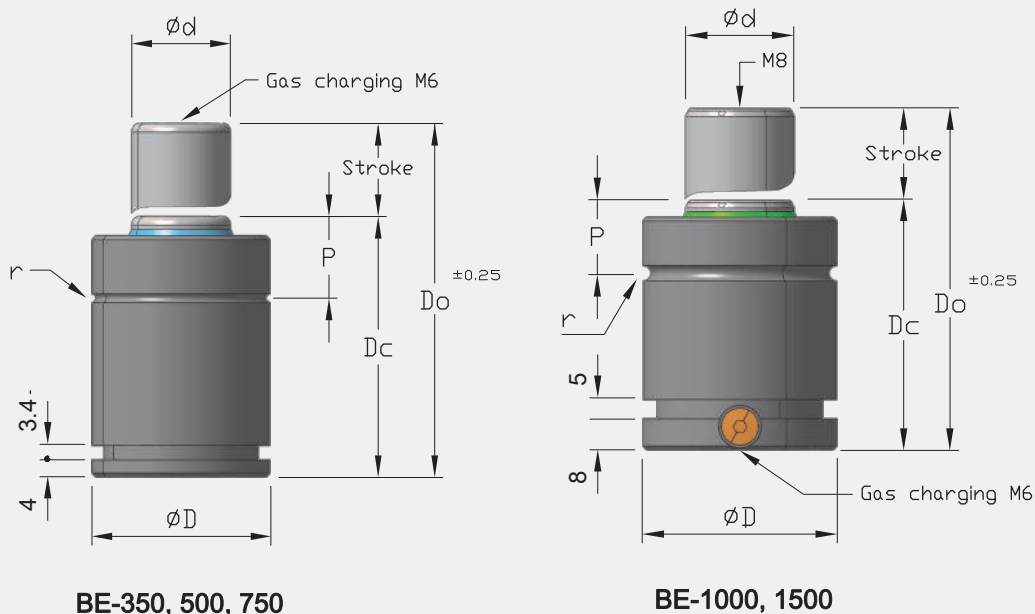

### Important!

Pressure medium: **Nitrogen Gas (N<sub>2</sub>)**  
 Operating temperature: **0 to +80°C**  
 Force increase by temperature: **0,33% / °C**

### The Extra Compact Line (BE series)

Every Extra Compact gas spring combines the convenience of a self-contained gas spring with increased on-contact force and shorter body height.

### MODEL COMPARISON - BODY DIAMETER 50mm - STROKE 25mm

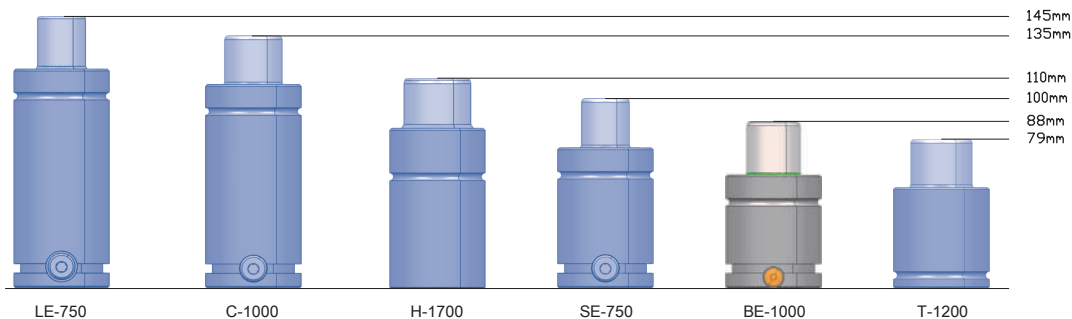





Part N°	Max. stem speed m/s	Max. charging pressure (bar)	Min. charging pressure (bar)	Order No for spare parts kit
BE-350	1.0	175	25	Kit BE-00350
BE-500	1.0	150	35	Kit BE-00500
BE-750	0.8	150	35	Kit BE-00750
BE-1000	1.0	150	35	Kit BE-01000
BE-1500	1.0	150	35	Kit BE-01500

Part N°						
BE-350	✓	✓	DS 32	DP 32	—	—
BE-500	✓	✓	DS / DSC 38	DP 38	—	—
BE-750	✓	✓	DS / DSC 45	DP 45	DB 45	DI 45
BE-1000	✓	✓	DS / DSC 50	DP 50	DB 50	DI 50
BE-1500	✓	✓	DS / DSC 63	DP 63	DB 63	DI 63

Flange Details: See pages 50-56

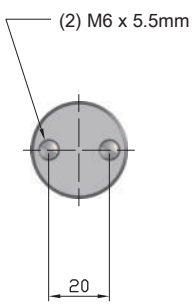
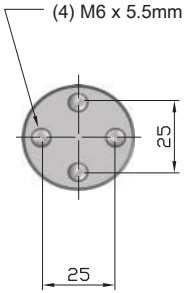
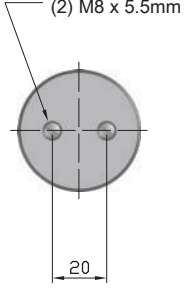
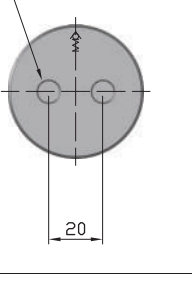
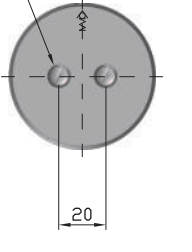

Part N° Model x stroke (mm)	Do mm	Dc mm	ØD mm	Ød mm	P mm	r mm	 bar	 daN	 daN	 Kg		Cylinder bases								
<b>BE-350 x 10</b>	50	40	32	16	12,5	1	175	350	525	0,16	-	 <p>(2) M6 x 5.5mm</p>								
13	56	43							530	0,17										
16	62	46							530	0,18										
19	68	49							530	0,19										
25	80	55							530	0,20										
32	94	62							530	0,22										
38	106	68							530	0,24										
50	130	80							530	0,28										
63	156	93							535	0,33										
75	180	105							535	0,36										
80	190	110							535	0,38										
100	230	130							535	0,44										
125	280	155							535	0,51										
<b>BE-500 x 10</b>	50	40							38	20			12,5	1	150	470	650	0,25	-	 <p>(4) M6 x 5.5mm</p>
13	56	43	655	0,26																
16	62	46	670	0,27																
19	68	49	670	0,28																
25	80	55	675	0,32																
32	94	62	680	0,34																
38	106	68	685	0,38																
50	130	80	690	0,42																
63	156	93	690	0,46																
75	180	105	695	0,50																
80	190	110	700	0,53																
100	230	130	700	0,55																
125	280	155	710	0,68																
<b>BE-750 x 13</b>	58	45	45	25	16,5	1	150	740			1245	0,35					-	 <p>(2) M8 x 5.5mm</p>		
16	64	48							1245	0,39										
19	70	51							1250	0,40										
25	82	57							1255	0,44										
32	96	64							1255	0,47										
38	108	70							1255	0,50										
50	132	82							1260	0,59										
63	158	95							1260	0,65										
75	182	107							1265	0,80										
80	192	112							1265	0,85										
100	232	132							1265	0,98										
125	282	157							1270	1,15										
<b>BE-1000 x 13</b>	64	51							50	28	17,5	2	150	925	1295	0,53			-	 <p>(2) M8 x 6mm</p>
16	70	54													1310	0,55				
19	76	57	1340	0,58																
25	88	63	1385	0,62																
32	102	70	1410	0,67																
38	114	76	1445	0,72																
50	138	88	1470	0,82																
63	164	101	1485	0,93																
75	188	113	1495	1,10																
80	198	118	1510	1,15																
100	238	138	1525	1,25																
125	288	163	1540	1,45																
<b>BE-1500 x 13</b>	70	57	63	36	19	2	150	1500							2250	0,95	-	 <p>(2) M8 x 7mm</p>		
16	76	60													2280	0,97				
19	82	63							2345	1,15										
25	94	69							2400	1,27										
32	108	76							2455	1,35										
38	120	82							2470	1,40										
50	144	94							2495	1,55										
63	170	107							2530	1,71										
75	194	119							2560	1,83										
80	204	124							2575	1,95										
100	244	144							2590	2,32										
125	294	169							2610	2,82										

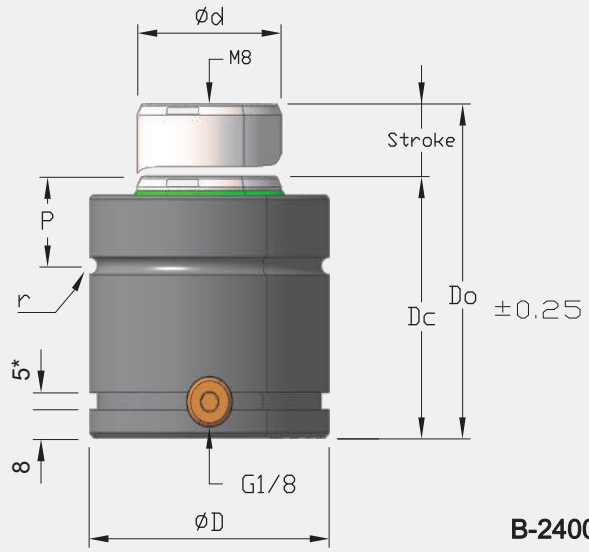

B-2400, 4200, 6600, 9500, 20000  
\*8 on BE-20000

**Important!**

Pressure medium: **Nitrogen Gas (N<sub>2</sub>)**  
 Operating temperature: **0 to +80°C**  
 Force increase by temperature: **0,33% / °C**

**The Extra Compact Line (BE series)**

Every Extra Compact gas spring combines the convenience of a self-contained gas spring with increased on-contact force and shorter body height.

**MODEL COMPARISON - BODY DIAMETER 50mm - STROKE 25mm**

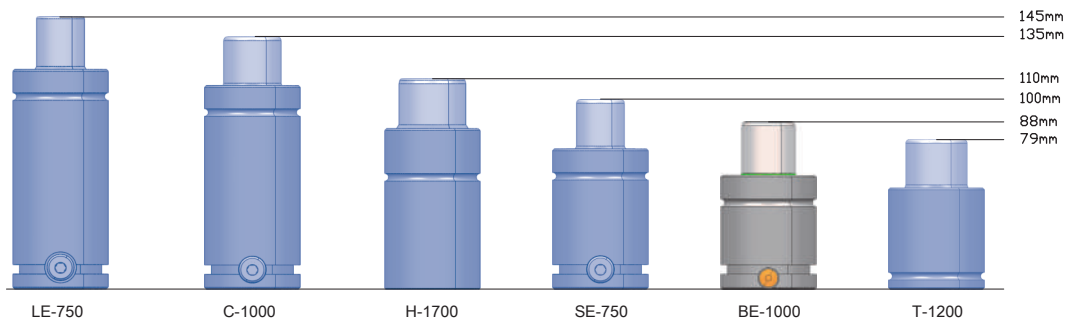

Part N°	Max. stem speed m/s	Max. charging pressure (bar)	Min. charging pressure (bar)	Order No for spare parts kit
BE-2400	1.0	150	35	Kit BE-02400
BE-4200	1.0	150	35	Kit BE-04200
BE-6600	0.8	150	35	Kit BE-06600
BE-9500	0.6	150	35	Kit BE-09500
BE-20000	0.5	150	35	Kit BE-20000

Part N°						
BE-2400	✓	✓	DS / DSC 75	DP 75	DB 75	DI 75
BE-4200	✓	✓	DS / DSC 95	DP 95	DB 95	DI 95
BE-6600	✓	✓	DS / DSC 120	DP 120	DB 120	DI 120
BE-9500	✓	✓	DS / DSC 150	DP 150	DB 150	—
BE-20000	✓	✓	DS / DSC 195	DP 195	DB 195	—

Flange Details: See pages 50-56



Part N° Model x stroke (mm)	Do mm	Dc mm	ØD mm	Ød mm	P mm	r mm	bar	daN	daN	Kg		Cylinder bases
<b>BE-2400 x 16</b>	77	61	75,2	45	21	2,5	150	2400	3540	1,40	✓	<p>(4) M8 x 10mm Ø40</p>
19	83	64							3585	1,43		
25	95	70							3645	1,45		
32	109	77							3700	1,65		
38	121	83							3730	1,70		
50	145	95							3770	1,80		
63	171	108							3790	2,10		
75	195	120							3820	2,15		
80	205	125							3845	2,25		
100	245	145							3865	2,60		
125	295	170							3895	3,10		
<b>BE-4200 x 16</b>	90	74							95	60		
19	96	77	6275	2,90								
25	108	83	6465	3,10								
32	122	90	6625	3,25								
38	134	96	6745	3,70								
50	158	108	6880	3,90								
63	184	121	6990	4,40								
75	208	133	7060	4,75								
80	218	138	7100	4,90								
100	258	158	7175	6,00								
125	308	183	7225	6,50								
<b>BE-6600 x 16</b>	100	84	120	75	25,5	2,5	150	6600			8775	5,20
19	106	87							8995	5,35		
25	118	93							9345	5,40		
32	132	100							9650	5,60		
38	144	106							9855	5,95		
50	168	118							10160	6,30		
63	194	131							10400	6,70		
75	218	143							10585	7,05		
80	228	148							10620	7,55		
100	268	168							10805	8,40		
125	318	193							10940	9,45		
<b>BE-9500 x 16</b>	110	94							150	90	27,5	2,5
19	116	97	13200	9,60								
25	128	103	13620	9,85								
32	142	110	13950	10,50								
38	154	116	14155	10,85								
50	178	128	14475	11,45								
63	204	141	14690	12,05								
75	228	153	14865	12,45								
80	238	158	14910	13,70								
100	278	178	15105	14,80								
125	328	203	15210	15,75								
<b>BE-20000 x 16</b>	142	126	195	130	33,5	2,5	150	20000				
19	148	129							25925	21,45		
25	160	135							26840	22,10		
32	174	142							27635	22,85		
38	186	148							28160	23,45		
50	210	160							28970	24,70		
63	236	173							29585	26,10		
75	260	185							30025	27,25		
80	270	190							30110	28,20		
100	310	210							30525	31,10		
125	360	235							30900	35,20		

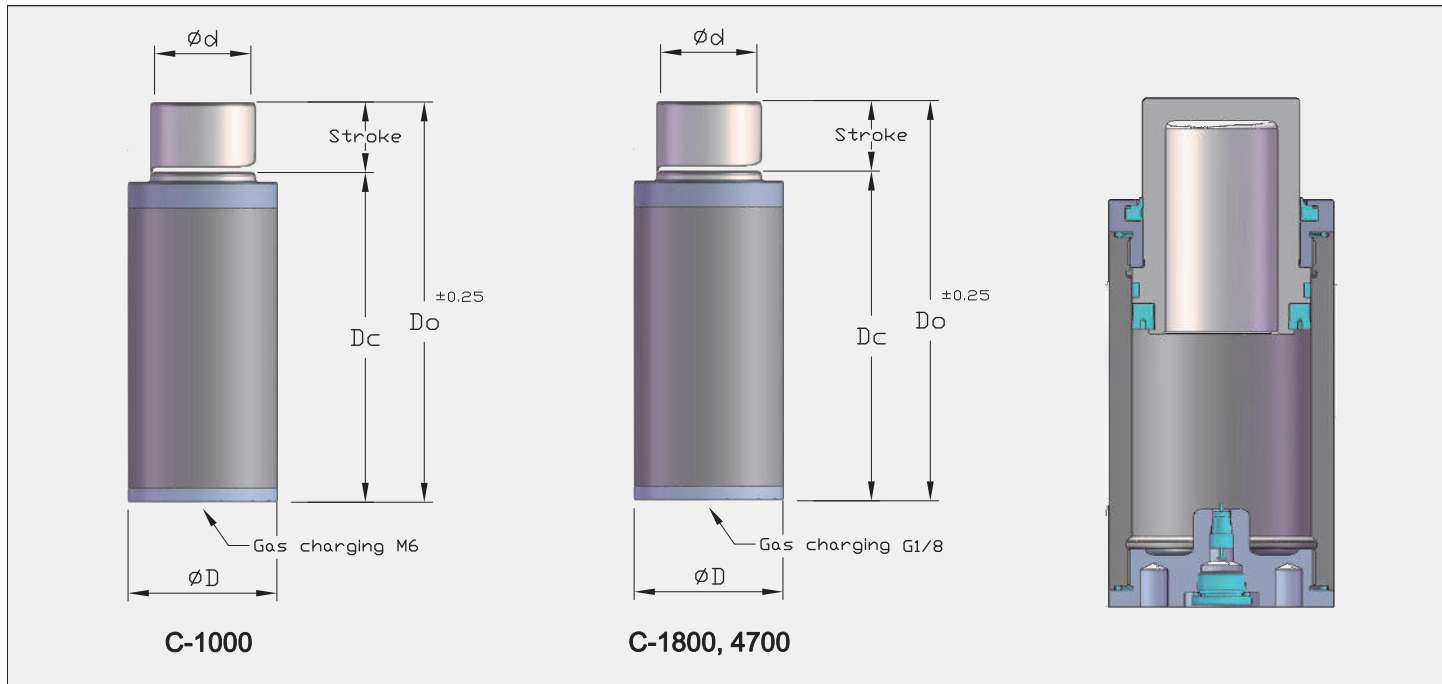

**Important!**

Pressure medium: **Nitrogen Gas (N<sub>2</sub>)**  
 Operating temperature: **0 to +80°C**  
 Force increase by temperature: **0,33% / °C**

**The Sub Compact Line (C series)**

Every DESIGN<sub>2</sub>-TITE® Sub Compact gas spring combines the convenience of a self-contained gas spring with increased on-contact force and shorter body height.

**SinterLube® Top Cap**

- Solid steel top cap with revolutionary SinterLube® lining.
- Designed with greater bearing area for improved support and guiding (A)
- Threaded construction creates greater structural strength and safety.

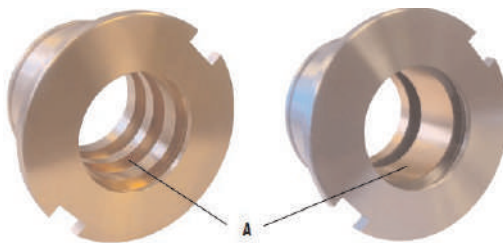

SinterLube® is a proprietary alloy material having good sliding lubricity and hardness which we have successfully used for years in guide bushings. We have now adapted this same technology to manufacturing a new line of top caps for our C series of nitrogen gas springs.

Part N°	Max. stem speed m/min	Max. charging pressure (bar)	Min. charging pressure (bar)	Order No for Spare Parts Kit
C-1000	20	150	50	C-1000-SK
C-1800	20	150	50	C-1800-SK
C-4700	20	150	50	C-4700-SK

Part N°						
C-1000	✓	✓	—	—	—	—
C-1800	✓	✓	—	—	—	DI 50
C-4700	✓	✓	—	—	—	DI 75

Flange Details: See pages 50-56





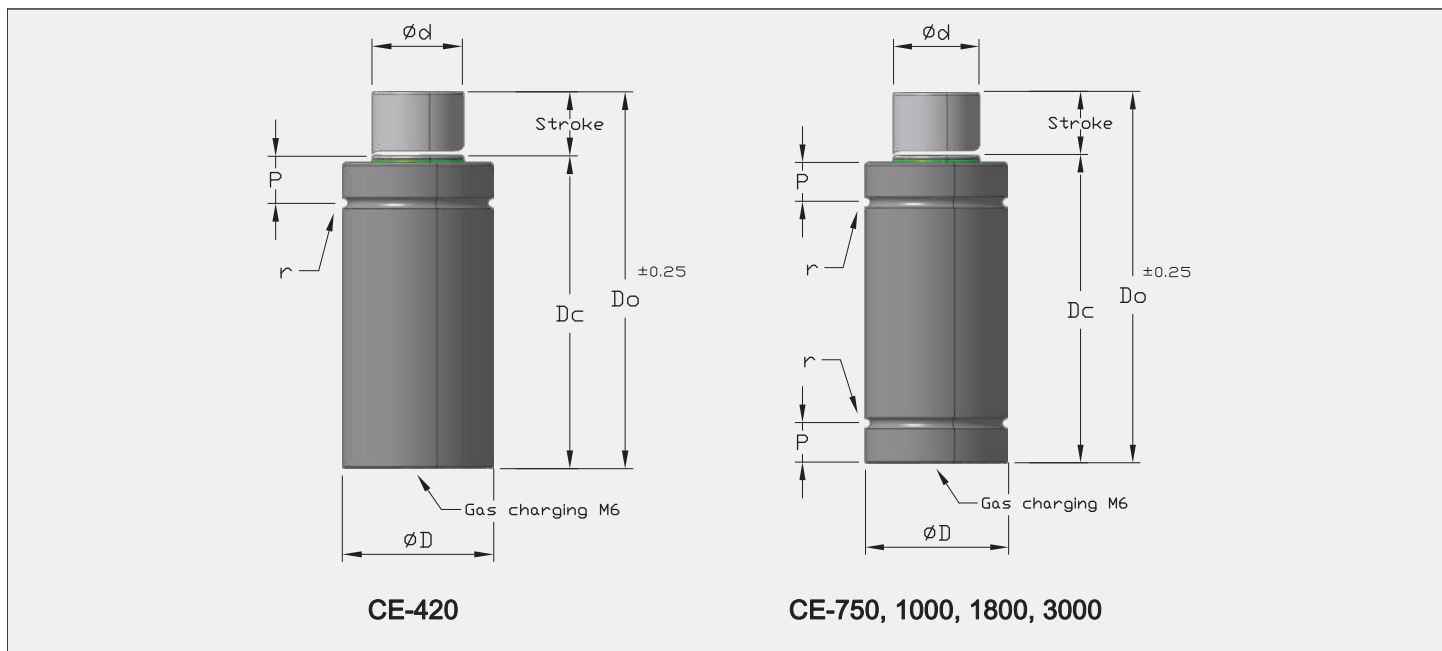

**Important!**

Pressure medium: **Nitrogen Gas (N<sub>2</sub>)**  
 Operating temperature: **0 to +80°C**  
 Force increase by temperature: **0,33% / °C**

**The Sub Compact Line (CE series)**

Every Sub Compact gas spring combines the convenience of a self-contained gas spring with increased on-contact force and shorter body height.

**MODEL COMPARISON - BODY DIAMETER 50mm - STROKE 25mm**

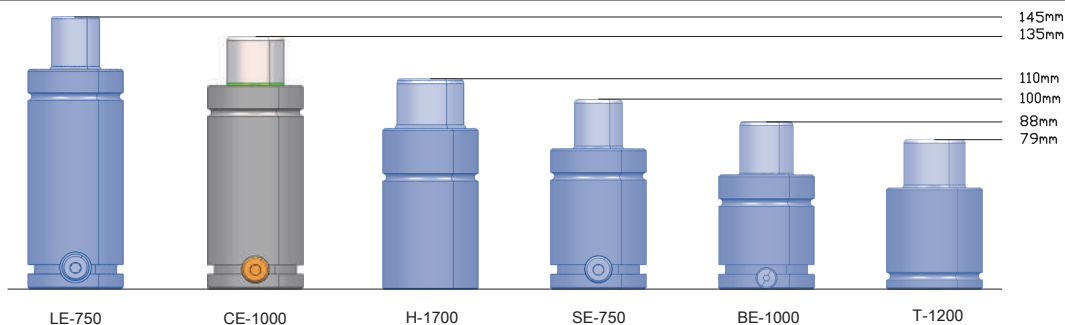

Part N°	Max. stem speed m/min	Max. charging pressure (bar)	Min. charging pressure (bar)	Order No for Spare Parts Kit
CE-420	20	150	50	Kit CE-00420
CE-750	20	150	50	Kit CE-00750
CE-1000	20	150	50	Kit CE-01000
CE-1800	20	150	50	Kit CE-01800
CE-3000	20	150	50	Kit CE-03000

Part N°						
CE-420	✓	✓	DS 25	—	—	—
CE-750	✓	✓	DS / DSC 32	—	—	—
CE-1000	✓	✓	DS / DSC 38	—	—	—
CE-1800	✓	✓	DS / DSC 50	—	—	DI 50
CE-3000	✓	✓	DS / DSC 63	—	—	—

Flange Details: See pages 50-56



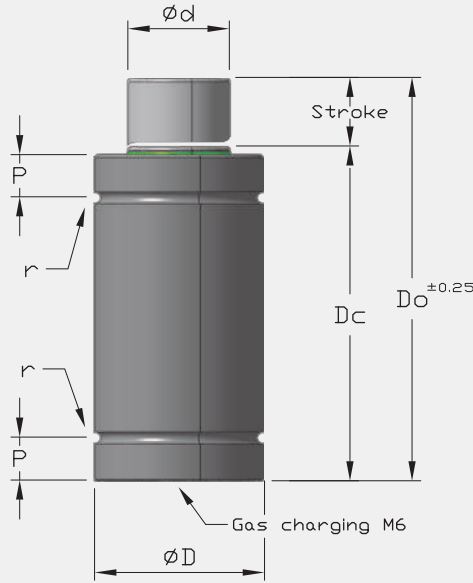

CE-4700, 7500, 11800, 18300

**Important!**

Pressure medium: **Nitrogen Gas (N<sub>2</sub>)**  
 Operating temperature: **0 to +80°C**  
 Force increase by temperature: **0,33% / °C**

**The Sub Compact Line (CE series)**

Every Sub Compact gas spring combines the convenience of a self-contained gas spring with increased on-contact force and shorter body height.

**MODEL COMPARISON - BODY DIAMETER 50mm - STROKE 25mm**

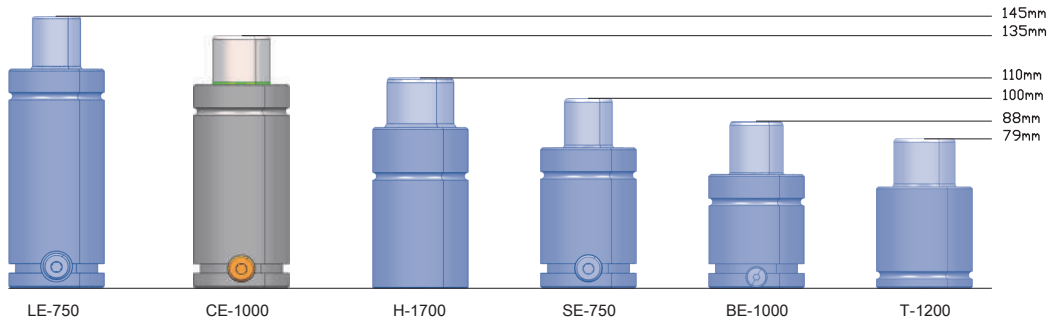

Part N°	Max. stem speed m/min	Max. charging pressure (bar)	Min. charging pressure (bar)	Order No for Spare Parts Kit
CE-4700	20	150	50	Kit CE-04700
CE-7500	20	150	50	Kit CE-07500
CE-11800	20	150	50	Kit CE-11800
CE-18300	20	150	50	Kit CE-18300

Part N°						
CE-4700	✓	✓	DS / DSC 75	—	—	DI 75
CE-7500	✓	✓	DS / DSC 95	—	—	DI 95
CE-11800	✓	✓	DS / DSC 120	—	—	DI 120
CE-18300	✓	✓	DS / DSC 150	—	—	—

Flange Details: See pages 50-56



Part N° Model x stroke (mm)	Do mm	Dc mm	ØD mm	Ød mm	P mm	r mm	bar	daN	daN	Kg		Cylinder bases
<b>CE-4700 x 10</b>	80	70	75	45	18	2,5	150	4700	7490	1,50	—	
<b>16</b>	106	90							7175	1,78		
<b>25</b>	135	110							7500	2,10		
<b>32</b>	167	135							7150	2,32		
<b>40</b>	200	160							7045	2,65		
<b>50</b>	240	190							7010	3,05		
<b>CE-7500 x 10</b>	90	80	95	60	21	2,5	150	7500	11720	3,10	—	
<b>16</b>	116	100							11350	3,30		
<b>25</b>	145	120							12025	3,85		
<b>32</b>	182	150							11160	4,46		
<b>40</b>	210	170							11315	4,69		
<b>50</b>	255	205							11040	5,50		
<b>CE-11800 x 10</b>	100	90	119,5	70	22,5	2,5	150	11800	17650	5,60	—	
<b>16</b>	126	110							17480	6,39		
<b>25</b>	155	130							18140	7,15		
<b>32</b>	187	155							17630	7,96		
<b>40</b>	220	180							17420	8,91		
<b>50</b>	260	210							17395	10,15		
<b>CE-18300 x 10</b>	110	100	149,5	90	24,5	2,5	150	18300	25050	9,10	—	
<b>16</b>	136	120							25395	9,95		
<b>25</b>	165	140							26640	10,80		
<b>32</b>	197	165							26180	13,26		
<b>40</b>	235	195							25795	15,10		
<b>50</b>	270	220							26275	16,80		

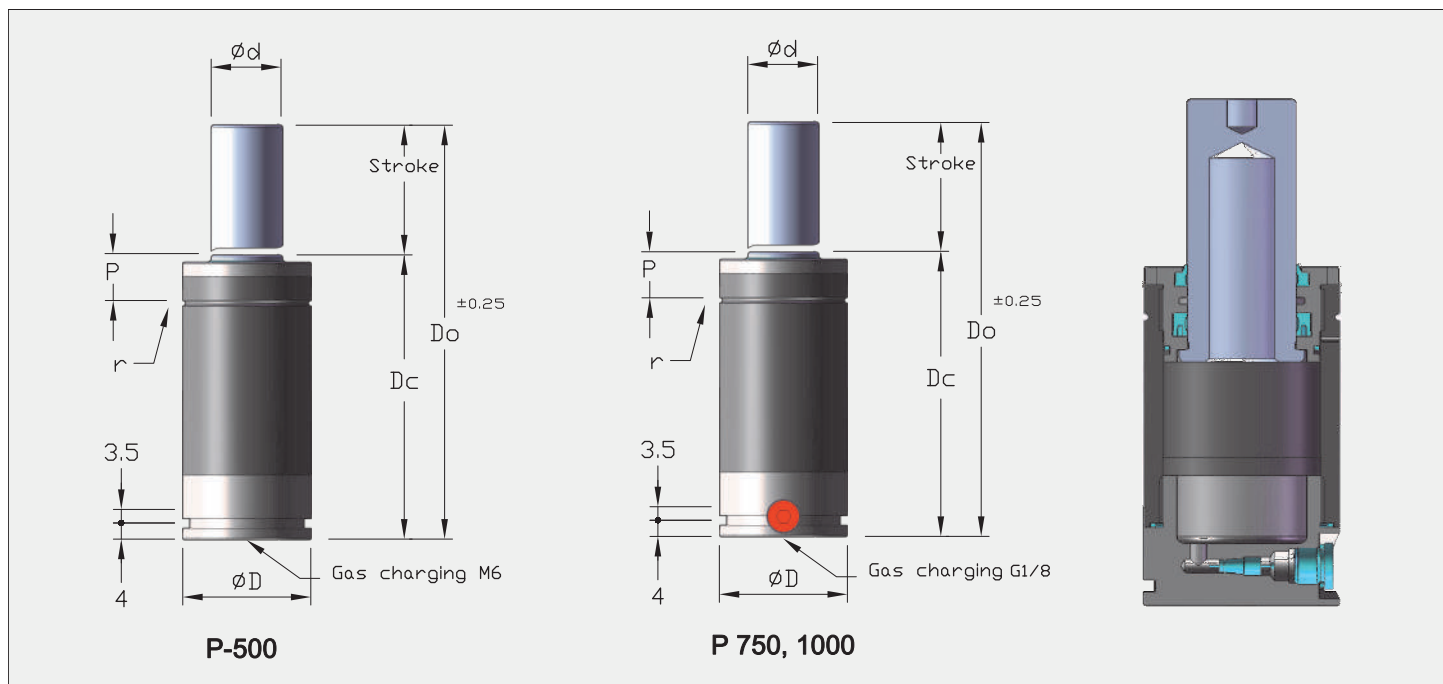

**Important!**

Pressure medium: **Nitrogen Gas (N<sub>2</sub>)**  
 Operating temperature: **0 to +80°C**  
 Force increase by temperature: **0,33% / °C**

**The Performance Line (P series)**

Every DESIGN<sub>2</sub>-TITE® Performance gas spring provides greater force in a smaller body than the S and L series gas springs.

**SinterLube® Top Cap**

- Solid steel top cap with revolutionary SinterLube® lining.
- Designed with greater bearing area for improved support and guiding (A)
- Threaded construction creates greater structural strength and safety.

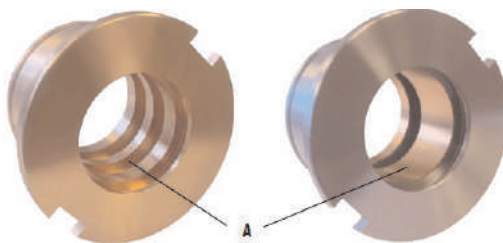

SinterLube® is a proprietary alloy material having good sliding lubricity and hardness which we have successfully used for years in guide bushings. We have now adapted this same technology to manufacturing a new line of top caps for our P series of nitrogen gas springs.

Part N°	Max. stem speed m/s	Max. charging pressure (bar)	Min. charging pressure (bar)	Order No for Spare Parts Kit
P-500	0.5	150	50	P-500-SK
P-750	0.8	150	50	P-750-SK
P-1000	0.8	150	50	P-1000-SK

Part N°						
P-500	✓	✓	DS / DSC 38	DP 38	—	—
P-750	✓	✓	DS / DSC 45	DP 45	DB 45	DI 45
P-1000	✓	✓	DS / DSC 50	DP 50	DB 50	DI 50

Flange Details: See pages 50-56



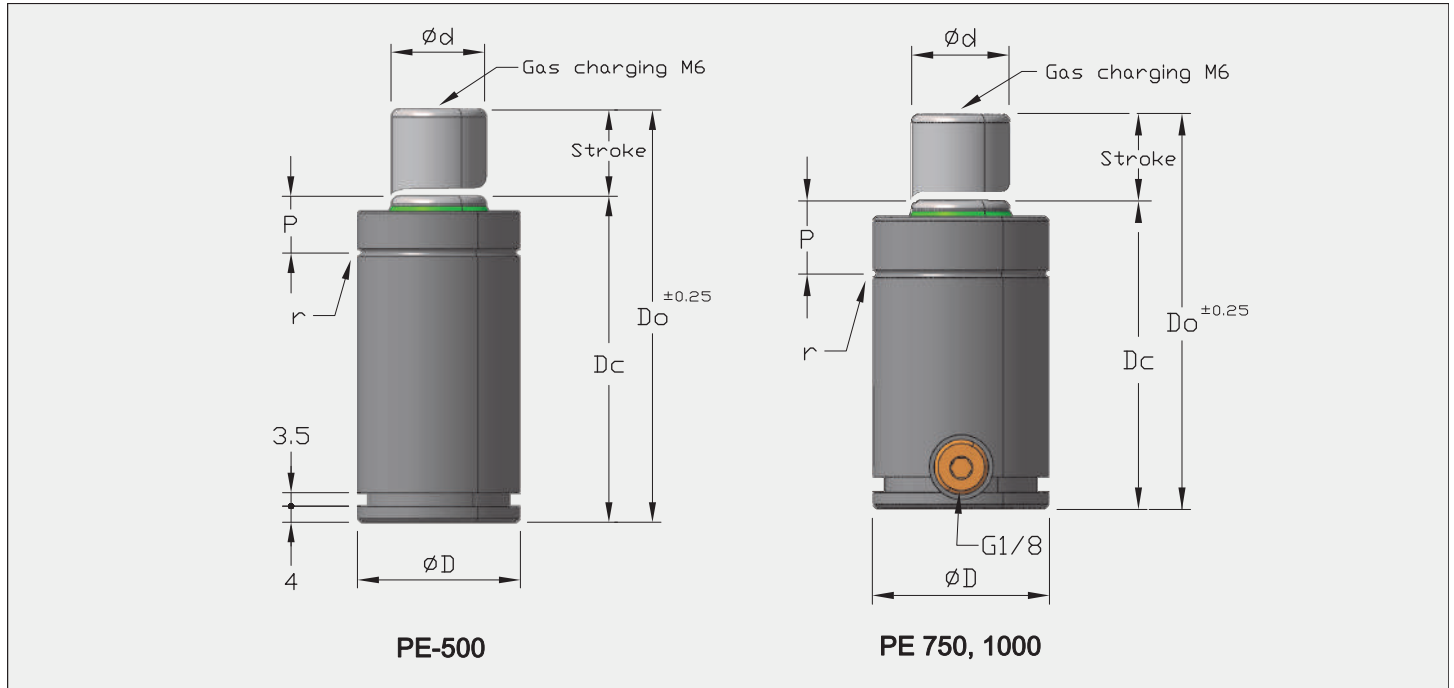

**Important!**

Pressure medium: **Nitrogen Gas (N<sub>2</sub>)**  
 Operating temperature: **0 to +80°C**  
 Force increase by temperature: **0,33% / °C**

**The Performance Line (PE series)**

Every performance gas spring provides greater force in a smaller body than the SE and LE series gas springs.

**MODEL COMPARISON - BODY DIAMETER 50mm - STROKE 25mm**

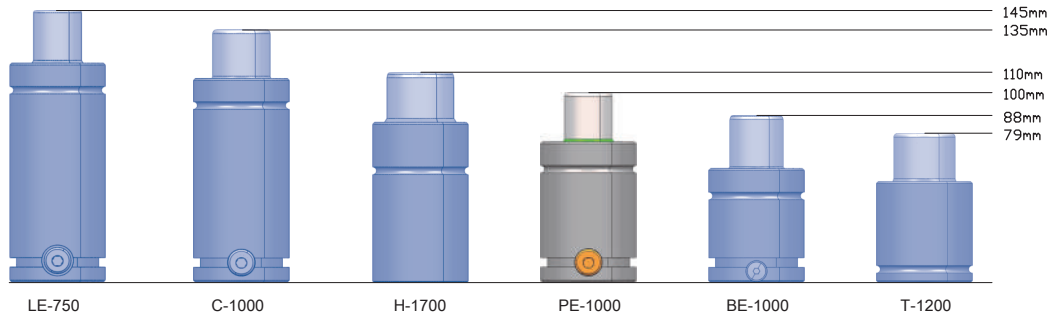

Part N°	Max. stem speed m/s	Max. charging pressure (bar)	Min. charging pressure (bar)	Order No for Spare Parts Kit
PE-500	1.0	150	35	Kit PE-0500
PE-750	0.8	150	35	Kit PE-0750
PE-1000	0.8	150	35	Kit PE-1000

Part N°						
PE-500	✓	✓	DS / DSC 38	DP 38	—	—
PE-750	✓	✓	DS / DSC 45	DP 45	DB 45	DI 45
PE-1000	✓	✓	DS / DSC 50	DP 50	DB 50	DI 50

Flange Details: See pages 50-56





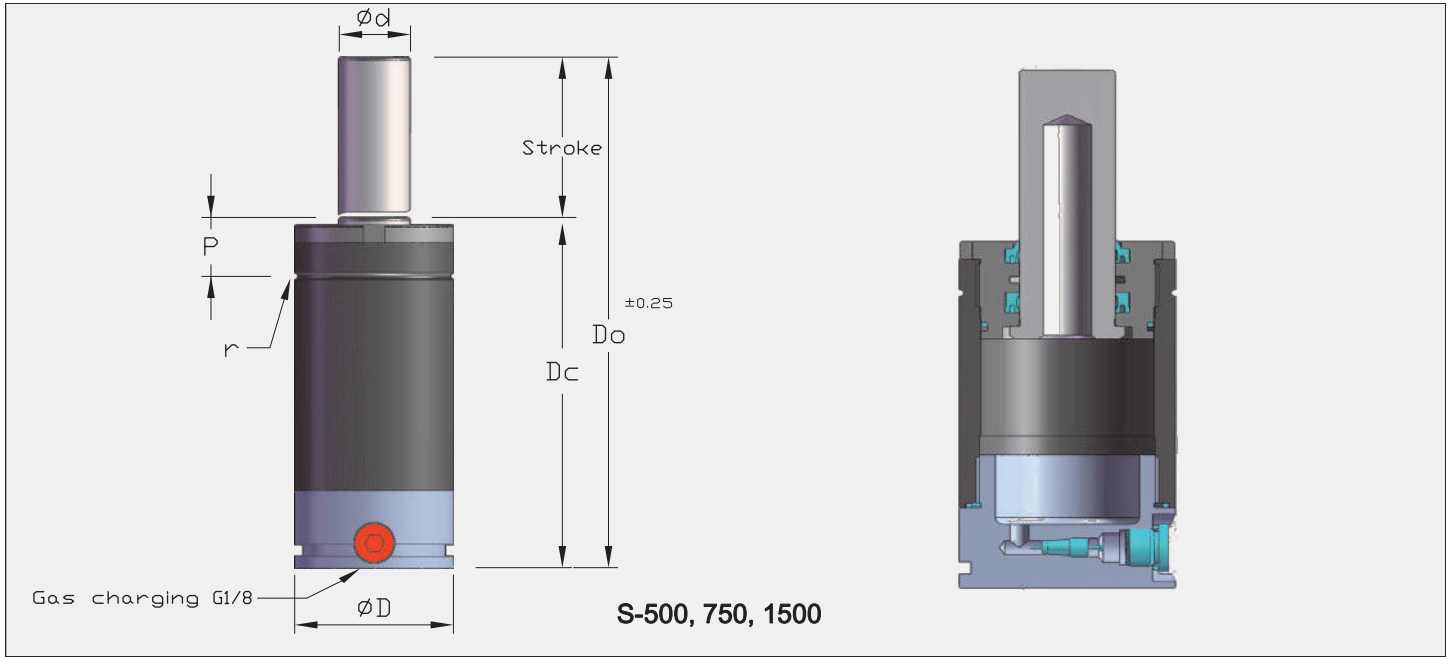

### Important!

Pressure medium: **Nitrogen Gas (N<sub>2</sub>)**  
 Operating temperature: **0 to +80°C**  
 Force increase by temperature: **0,33% / °C**

### The North American Line (S series)

Every DESIGN<sub>2</sub>-TITE® North American gas spring meets all ISO and VDI piston rod and body diameter standards, in addition to mounting and charge port specifications and features the shorter body height common in North America.

### SinterLube® Top Cap

- Solid steel top cap with revolutionary SinterLube® lining.
- Designed with greater bearing area for improved support and guiding (A)
- Threaded construction creates greater structural strength and safety.

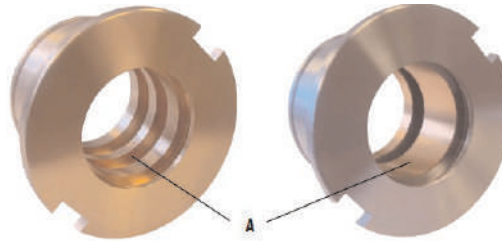

SinterLube® is a proprietary alloy material having good sliding lubricity and hardness which we have successfully used for years in guide bushings. We have now adapted this same technology to manufacturing a new line of top caps for our S series of nitrogen gas springs.

Part N°	Max. stem speed m/s	Max. charging pressure (bar)	Min. charging pressure (bar)	Order No for Spare Parts Kit
S-500	1.2	150	50	S/L-500-SK
S-750	1.2	150	50	S/L-750-SK
S-1500	1.2	150	50	S/L-1500-SK

Part N°						
S-500	✓	✓	DS / DSC 45	DP 45	DB 45	DI 45
S-750	✓	✓	DS / DSC 50	DP 50	DB 50	DI 50
S-1500	✓	✓	DS / DSC 75	DP 75	DB 75	DI 75

Flange Details: See pages 50-56



Part N° Model x stroke (mm)	Do mm	Dc mm	ØD mm	Ød mm	P mm	r mm	bar	daN	daN	Kg		Cylinder bases								
<b>S-500 x 6</b>	62	56	45	20	16,5	1	150	470	670	0.65	✓									
<b>13</b>	76	63							709	0.69										
<b>16</b>	82	66							716	0.71										
<b>19</b>	88	69							722	0.73										
<b>25</b>	100	75							729	0.77										
<b>38</b>	126	88							738	0.85										
<b>50</b>	150	100							746	0.93										
<b>63</b>	176	113							754	1.02										
<b>80</b>	210	130							761	1.14										
<b>100</b>	250	150							766	1.28										
<b>125</b>	300	175							771	1.45										
<b>S-750 x 6</b>	62	56							50	25			17.5	2	150	736	1070	0.79	✓	
<b>13</b>	76	63	1171	0.84																
<b>19</b>	88	69	1210	0.89																
<b>25</b>	100	75	1233	0.94																
<b>38</b>	126	88	1261	1.05																
<b>50</b>	150	100	1275	1.14																
<b>63</b>	176	113	1285	1.25																
<b>80</b>	210	130	1302	1.39																
<b>100</b>	250	150	1330	1.58																
<b>125</b>	300	175	1354	1.82																
<b>S-1500 x 13</b>	127	114	75	36	21	2,5	150	1527			1788	3.10					✓			
<b>25</b>	151,6	126,6									1946	3.35								
<b>38</b>	177	139							2066	3.60										
<b>50</b>	201,6	151,6							2149	3.85										
<b>63</b>	227	164							2217	4.10										
<b>80</b>	261,6	181,6							2286	4.40										
<b>100</b>	301,5	201,6							2346	4.80										
<b>125</b>	351,6	226,6							2420	5.30										
<b>160</b>	421	261							2515	6.10										

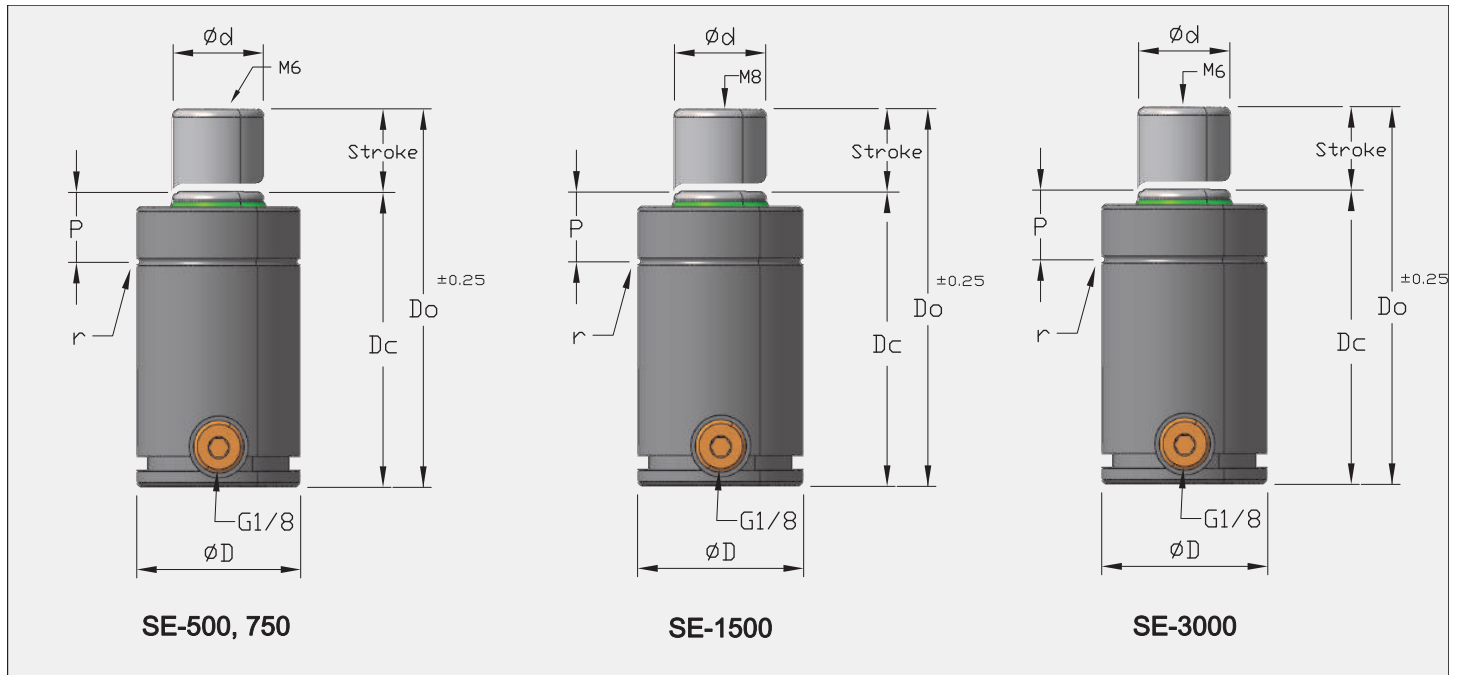

### Important!

Pressure medium: **Nitrogen Gas (N<sub>2</sub>)**  
 Operating temperature: **0 to +80°C**  
 Force increase by temperature: **0,33% / °C**

### The Renault Line (SE series)

Renault line gas spring meets all ISO and VDI piston rod and body diameter specification, and they conform to the mounting, charge port, and body height specifications of the Renault norms.

### MODEL COMPARISON - BODY DIAMETER 50mm - STROKE 25mm

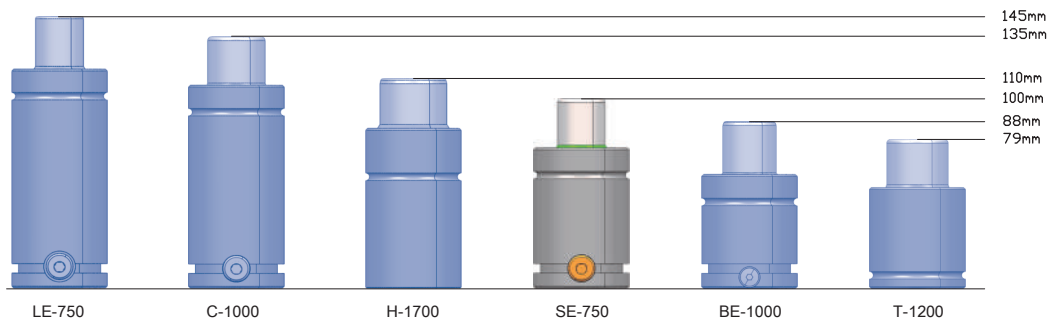

Part N°	Max. stem speed m/s	Max. charging pressure (bar)	Min. charging pressure (bar)	Order No for Spare Parts Kit
SE-500	1.2	150	35	Kit SE-00500
SE-750	1.2	150	35	Kit SE-00750
SE-1500	1.2	150	35	Kit SE-01500
SE-3000	0.8	150	35	Kit SE-03000

Part N°						
SE-500	✓	✓	DS / DSC 45	DP 45	DB 45	DI 45
SE-750	✓	✓	DS / DSC 50	DP 50	DB 50	DI 50
SE-1500	✓	✓	DS / DSC 75	DP 75	DB 75	DI 75
SE-3000	✓	✓	DS / DSC 95	DP 95	DB 95	DI 95

Flange Details: See pages 50-56



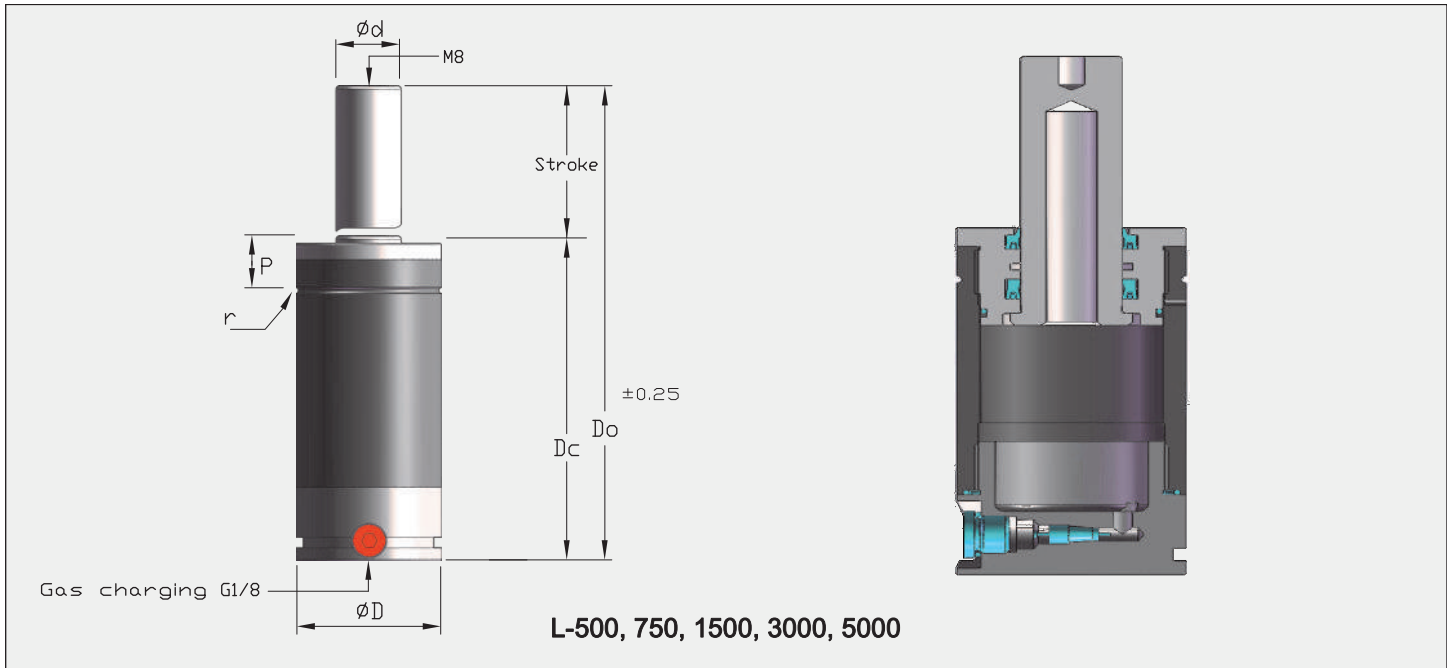

### Important!

Pressure medium: **Nitrogen Gas (N<sub>2</sub>)**  
 Operating temperature: **0 to +80°C**  
 Force increase by temperature: **0,33% / °C**

### The ISO Line (L series)

Every DESIGN<sub>2</sub>-TITE® ISO gas spring meets all ISO and VDI piston rod, body and height standards, in addition to mounting and charge port specifications.

### SinterLube® Top Cap

- Solid steel top cap with revolutionary SinterLube® lining.
- Designed with greater bearing area for improved support and guiding (A)
- Threaded construction creates greater structural strength and safety.

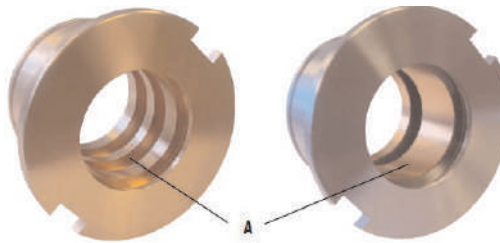

SinterLube® is a proprietary alloy material having good sliding lubricity and hardness which we have successfully used for years in guide bushings. We have now adapted this same technology to manufacturing a new line of top caps for our L series of nitrogen gas springs.

Part N°	Max. stem speed m/s	Max. charging pressure (bar)	Min. charging pressure (bar)	Order No for Spare Parts Kit
L-500	0.8	150	50	S/L-500-SK
L-750	0.8	150	50	S/L-750-SK
L-1500	0.8	150	50	S/L-1500-SK
L-3000	0.8	150	50	S/L-3000-SK
L-5000	0.5	150	50	S/L-5000-SK

Part N°						
L-500	✓	✓	DS / DSC 45	DP 45	DB 45	DI 45
L-750	✓	✓	DS / DSC 50	DP 50	DB 50	DI 50
L-1500	✓	✓	DS / DSC 75	DP 75	DB 75	DI 75
L-3000	✓	✓	DS / DSC 95	DP 95	DB 95	DI 95
L-5000	✓	✓	DS / DSC 120	DP 120	DB 120	DI 120

Flange Details: See pages 50-56



Part N° Model x stroke (mm)	Do mm	Dc mm	ØD mm	Ød mm	P mm	r mm	bar	daN	daN	Kg		Cylinder bases								
<b>L-500 x 10</b>	105	95	45	20	16,5	1	150	470	539	.94		(2) M8 x 12mm 								
<b>13</b>	111	98							553	.96										
<b>25</b>	135	110							564	.93										
<b>38</b>	161	123							625	1.12										
<b>50</b>	185	135							646	1.20										
<b>63</b>	211	148							664	1.29										
<b>80</b>	245	165							682	1.41										
<b>100</b>	285	185							697	1.55										
<b>125</b>	335	210							711	1.72										
<b>160</b>	405	245							725	1.97										
<b>L-750 x 13</b>	121	108							50	25			17,5	2	150	736	866	1.26		(2) M8 x 12mm 
<b>25</b>	145	120	944	1.35																
<b>38</b>	171	133	1003	1.46																
<b>50</b>	195	145	1043	1.56																
<b>63</b>	221	158	1077	1.66																
<b>80</b>	255	175	1115	1.81																
<b>100</b>	295	195	1156	1.99																
<b>125</b>	345	220	1196	2.25																
<b>160</b>	415	255	1237	2.55																
<b>200</b>	495	295	1271	2.95																
<b>L-1500 x 13</b>	136	123	75	36	21	2,5	150	1527			1745	3.25						(4) M8 x 12mm 		
<b>25</b>	160	135							1887	3.45										
<b>38</b>	186	148							2001	3.70										
<b>50</b>	210	160							2081	3.95										
<b>63</b>	236	173							2151	4.20										
<b>80</b>	270	190							2222	4.50										
<b>100</b>	310	210							2285	4.90										
<b>125</b>	360	235							2362	5.45										
<b>160</b>	430	270							2459	6.20										
<b>200</b>	510	310							2543	7.15										
<b>L-3000 x 25</b>	170	145							95	50	24	2,5	150	2945	3780	6.10				(4) M8 x 12mm 
<b>38</b>	196	158	4240	6.85																
<b>50</b>	220	170	4434	7.20																
<b>63</b>	246	183	4596	7.60																
<b>80</b>	280	200	4756	8.10																
<b>100</b>	320	220	4897	8.75																
<b>125</b>	370	245	5030	9.50																
<b>160</b>	440	280	5290	10.85																
<b>200</b>	520	320	5519	12.40																
<b>L-5000 x 25</b>	190	165	120	65	25,5	2,5	150	4977							6138	10.65		(4) M10 x 11mm 		
<b>38</b>	216	178													6566	11.30				
<b>50</b>	240	190							6891	11.90										
<b>63</b>	266	203							7185	12.55										
<b>80</b>	300	220							7503	13.45										
<b>100</b>	340	240							7804	14.45										
<b>125</b>	390	265							8105	15.75										
<b>160</b>	460	300							8656	18.05										
<b>200</b>	540	340							9181	20.70										

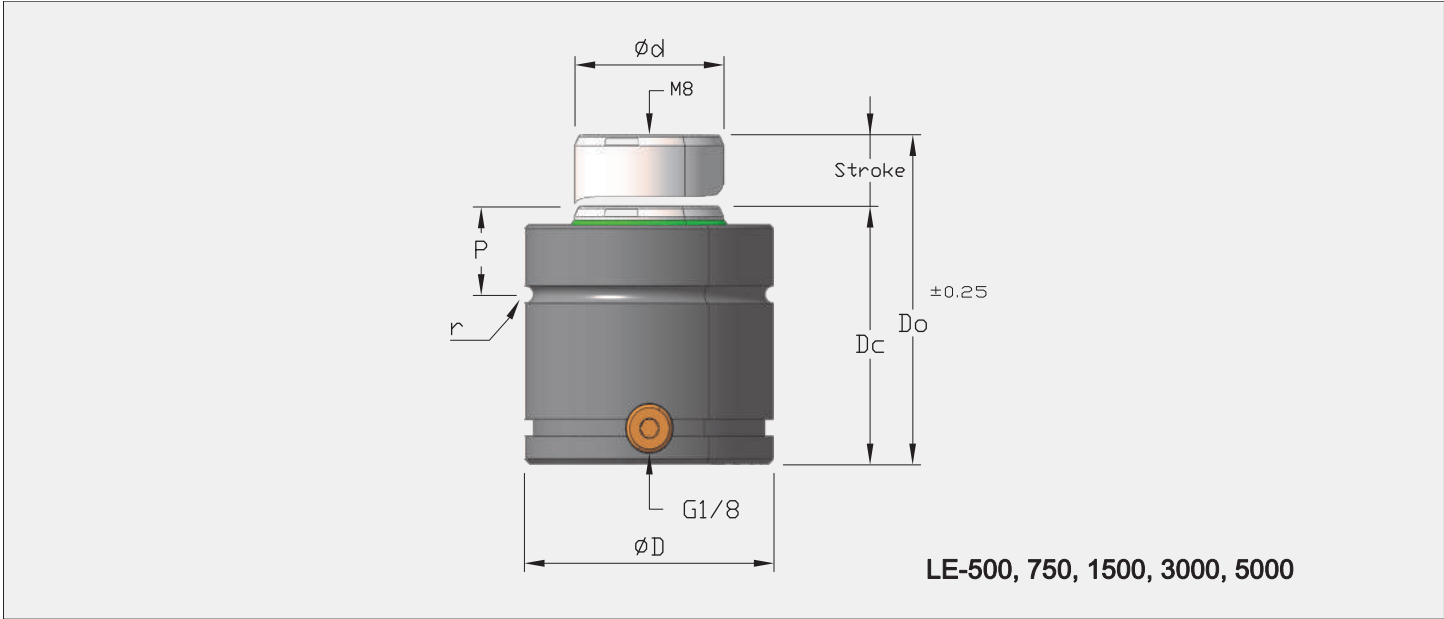

**Important!**

Pressure medium: **Nitrogen Gas (N<sub>2</sub>)**  
 Operating temperature: **0 to +80°C**  
 Force increase by temperature: **0,33% / °C**

**The ISO Line (LE series)**

Every ISO gas spring meets all ISO and VDI piston rod, body and height standards, in addition to mounting and charge port specifications.

**MODEL COMPARISON - BODY DIAMETER 50mm - STROKE 25mm**

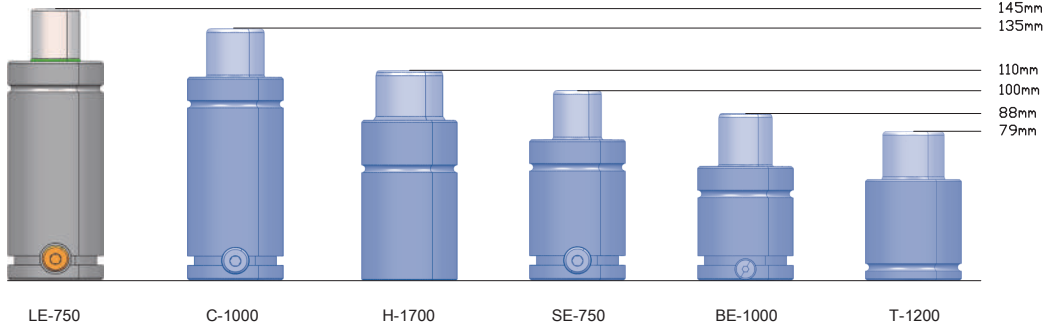

Part N°	Max. stem speed m/s	Max. charging pressure (bar)	Min. charging pressure (bar)	Order No for Spare Parts Kit
LE-500	1.0	150	35	Kit LE-00500
LE-750	0.8	150	35	Kit LE-00750
LE-1500	0.8	150	35	Kit LE-01500
LE-3000	0.8	150	35	Kit LE-03000
LE-5000	0.5	150	35	Kit LE-05000

Part N°						
LE-500	✓	✓	DS / DSC 45	DP 45	DB 45	DI 45
LE-750	✓	✓	DS / DSC 50	DP 50	DB 50	DI 50
LE-1500	✓	✓	DS / DSC 75	DP 75	DB 75	DI 75
LE-3000	✓	✓	DS / DSC 95	DP 95	DB 95	DI 95
LE-5000	✓	✓	DS / DSC 120	DP 120	DB 120	DI 120

**Flange Details:** See pages 50-56





Part N° Model x stroke (mm)	Do mm	Dc mm	ØD mm	Ød mm	P mm	r mm	bar	daN	daN	Kg		Cylinder bases
<b>LE-500 x 10</b>	105	95	45,2	20	16,5	1	150	470	575	0,87	✓	<p>(2) M8 x 12mm</p>
<b>13</b>	110,4	97,7							595	0,95		
<b>25</b>	135	110							645	0,99		
<b>38</b>	161	123							680	1,12		
<b>50</b>	185	135							710	1,21		
<b>63</b>	212	149							730	1,34		
<b>80</b>	245	165							745	1,50		
<b>100</b>	285	185							760	1,68		
<b>125</b>	335	210							780	2,00		
<b>160</b>	405	245							800	2,15		
<b>LE-750 x 13</b>	120,4	107,7							50	25		
<b>25</b>	145	120	965	1,35								
<b>38</b>	171	133	990	1,40								
<b>50</b>	195	145	1030	1,52								
<b>63</b>	222	159	1070	1,70								
<b>80</b>	255	175	1085	1,82								
<b>100</b>	295	195	1095	1,85								
<b>125</b>	345	220	1160	2,20								
<b>160</b>	415	255	1175	2,30								
<b>200</b>	495	295	1180	3,10								
<b>250</b>	595	345	1205	3,60								
<b>300</b>	695	395	1230	4,15								
<b>LE-1500 x 13</b>	135,4	122,7	75	36	21	2,5	148	1500	1740	3,15	✓	<p>(4) M8 x 12mm</p>
<b>25</b>	160	135							1845	3,30		
<b>38</b>	186	148							1900	3,50		
<b>50</b>	210	160							1940	3,65		
<b>63</b>	237	174							1980	3,90		
<b>80</b>	270	190							2075	4,45		
<b>100</b>	310	210							2095	4,80		
<b>125</b>	360	235							2125	5,36		
<b>160</b>	430	270							2150	6,10		
<b>200</b>	510	310							2185	7,15		
<b>250</b>	610	360							2200	7,86		
<b>300</b>	710	410	2225	8,86								
<b>LE-3000 x 25</b>	170	145	95	50	24	2,5	150	3000	3615	5,75	✓	<p>(4) M8 x 12mm</p>
<b>38</b>	196	158							3760	6,15		
<b>50</b>	220	170							3875	6,53		
<b>63</b>	247	184							4960	6,91		
<b>80</b>	280	200							4020	7,25		
<b>100</b>	320	220							4275	8,00		
<b>125</b>	370	245							4340	8,15		
<b>160</b>	440	280							4390	9,24		
<b>200</b>	520	320							4450	10,31		
<b>250</b>	620	370							4495	11,90		
<b>300</b>	720	420							4525	14,87		
<b>LE-5000 x 25</b>	190	165	120	65	25,5	2,5	150	5000	6275	12,01	✓	<p>(4) M8 x 11mm</p>
<b>38</b>	216	178							6600	12,85		
<b>50</b>	240	190							6830	13,60		
<b>63</b>	267	204							7010	14,50		
<b>80</b>	300	220							7195	15,39		
<b>100</b>	340	240							7340	16,48		
<b>125</b>	390	265							7495	18,05		
<b>160</b>	460	300							7610	19,83		
<b>200</b>	540	340							7700	21,70		
<b>250</b>	640	390							7795	23,85		
<b>300</b>	740	440							7850	25,60		

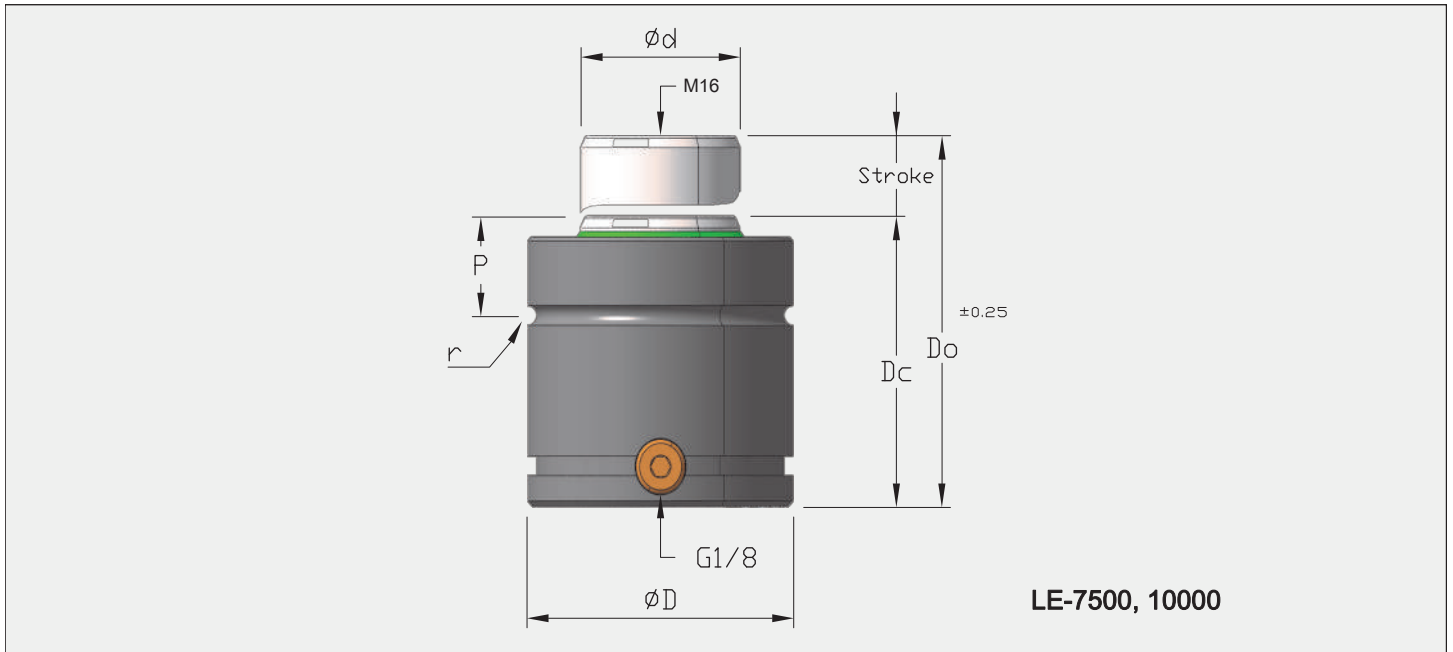

**Important!**

Pressure medium: **Nitrogen Gas (N<sub>2</sub>)**  
 Operating temperature: **0 to +80°C**  
 Force increase by temperature: **0,33% / °C**

**The ISO Line (LE series)**

Every ISO gas spring meets all ISO and VDI piston rod, body and height standards, in addition to mounting and charge port specifications.

**MODEL COMPARISON - BODY DIAMETER 50mm - STROKE 25mm**

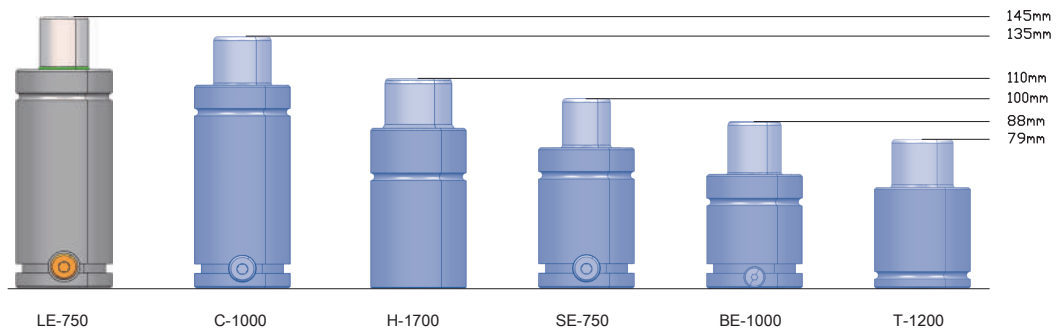

Part N°	Max. stem speed m/s	Max. charging pressure (bar)	Min. charging pressure (bar)	Order No for Spare Parts Kit
LE-7500	0.5	150	35	Kit LE-07500
LE-10000	0.5	150	35	Kit LE-10000

Part N°						
LE-7500	✓	✓	DS / DSC 150	DP 150	DB 150	DI 150
LE-10000	✓	✓	DS / DSC 195	DP 195	DB 195	—

**Flange Details:** See pages 50-56



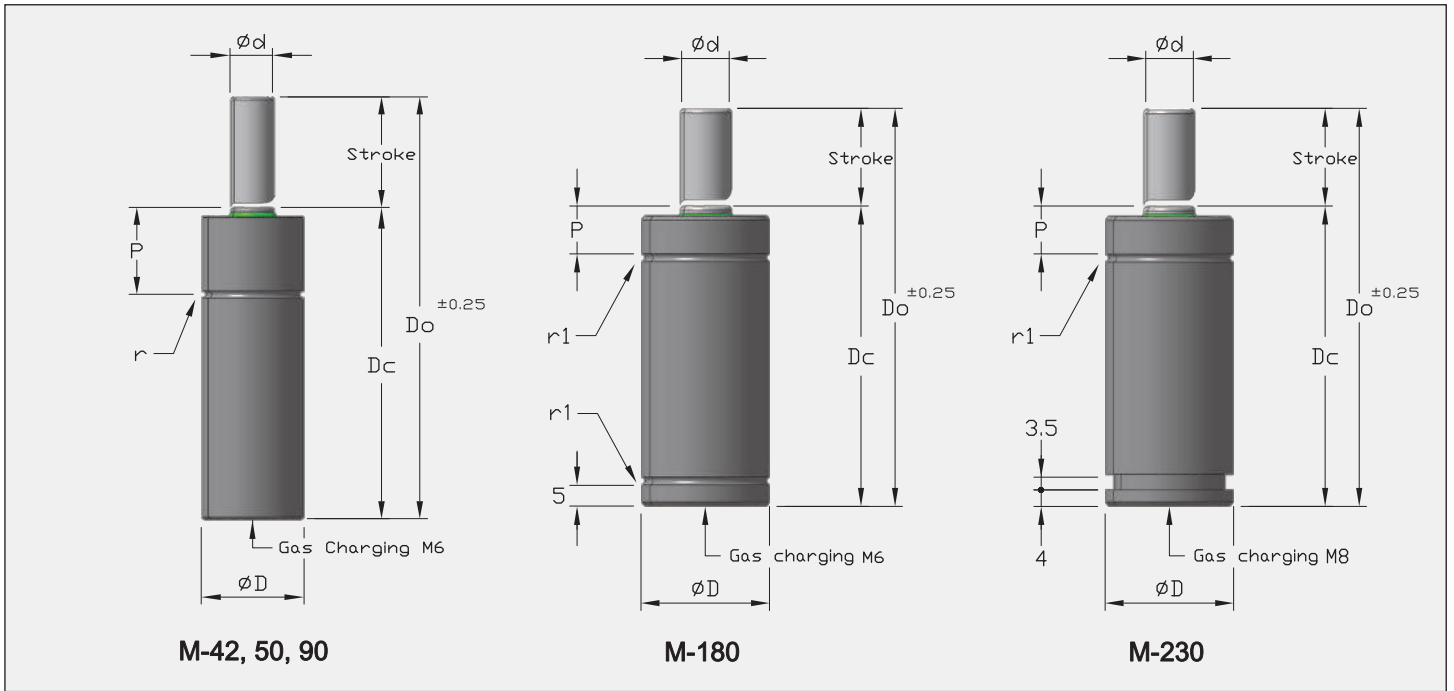

### Important!

Pressure medium: **Nitrogen Gas (N<sub>2</sub>)**  
 Operating temperature: **0 to +80°C**  
 Force increase by temperature: **0,33% / °C**

### The small ISO Line (M series)

Every small ISO gas spring meets all ISO and VDI piston rod, body and height standards, in the smallest of models.

### MODEL COMPARISON - BODY DIAMETER 50mm - STROKE 25mm

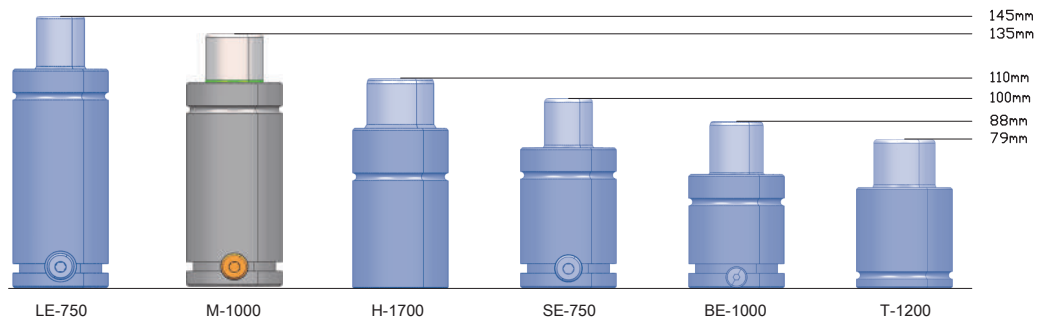

Part N°	Max. stem speed m/min	Max. charging pressure (bar)	Min. charging pressure (bar)	Order No for Spare Parts Kit
M-42	20	150	20	Kit M-00042
M-50	20	175	50	Kit M-00050
M-90	0.5 m/s	175	25	Kit M-00090
M-180	0.6 m/s	175	25	Kit M-00180
M-230	0.6 m/s	175	25	Kit M-00230

Part N°						
M-42	✓	✓	—	—	—	—
M-50	✓	✓	—	—	—	—
M-90	✓	✓	DS 19	—	—	—
M-180	✓	✓	DS 25	—	F 25	—
M-230	✓	✓	DS 32	DP 32	—	—

Flange Details: See pages 50-56



Part N° Model x stroke (mm)	Do mm	Dc mm	ØD mm	Ød mm	P mm	r mm	bar	daN	daN	Kg		Cylinder bases
<b>M-42 x 7</b>	56	49	12,2	6	—	—	150	42	≈ 65	0,03		
13	68	55					0,03					
15	72	57					0,04					
19	80	61					0,05					
25	92	67					0,05					
38	118	80					0,06					
50	142	92					0,06					
<b>M-50 x 15</b>	72	57	14,2	6	16,5	0,6	175	50	≈ 65	0,06		
25	92	67					0,08					
38	118	80					0,09					
50	142	92					0,10					
63	169	106					0,12					
80	205	125	0,15									
<b>M-90 x 7</b>	56	49	19,2	8	17	0,8	175	90	≈ 112	0,08		
10	62	52					0,08					
13	67,4	54,4					0,08					
15	72	57					0,09					
25	92	67					0,10					
38	118	80					0,12					
50	142	92					0,13					
63	168	105					0,15					
80	202	122					0,17					
100	245	145	0,18									
125	295	170	0,21									
<b>M-180 x 7</b>	56	49	25	12	16	1	175	200	≈ 270	0,13		
10	62	52					0,14					
13	67,4	54,7					0,14					
15	72	57					0,15					
16	74,3	58,3					0,15					
25	92	67					0,16					
38	118	80					0,19					
50	142	92					0,21					
63	172	109					0,25					
80	205	125					0,26					
100	245	145					0,29					
125	295	170					0,33					
<b>M-230 x 10</b>	70	60	32	12	10,5	1	175	200	≈ 270	0,30		
13	75,4	62,7					0,32					
16	82	66					0,33					
25	100	75					0,37					
38	126	88					0,42					
50	150	100					0,47					
63	177	114					0,52					
80	210	130	0,60									
100	250	150	0,75									
125	300	175	0,85									

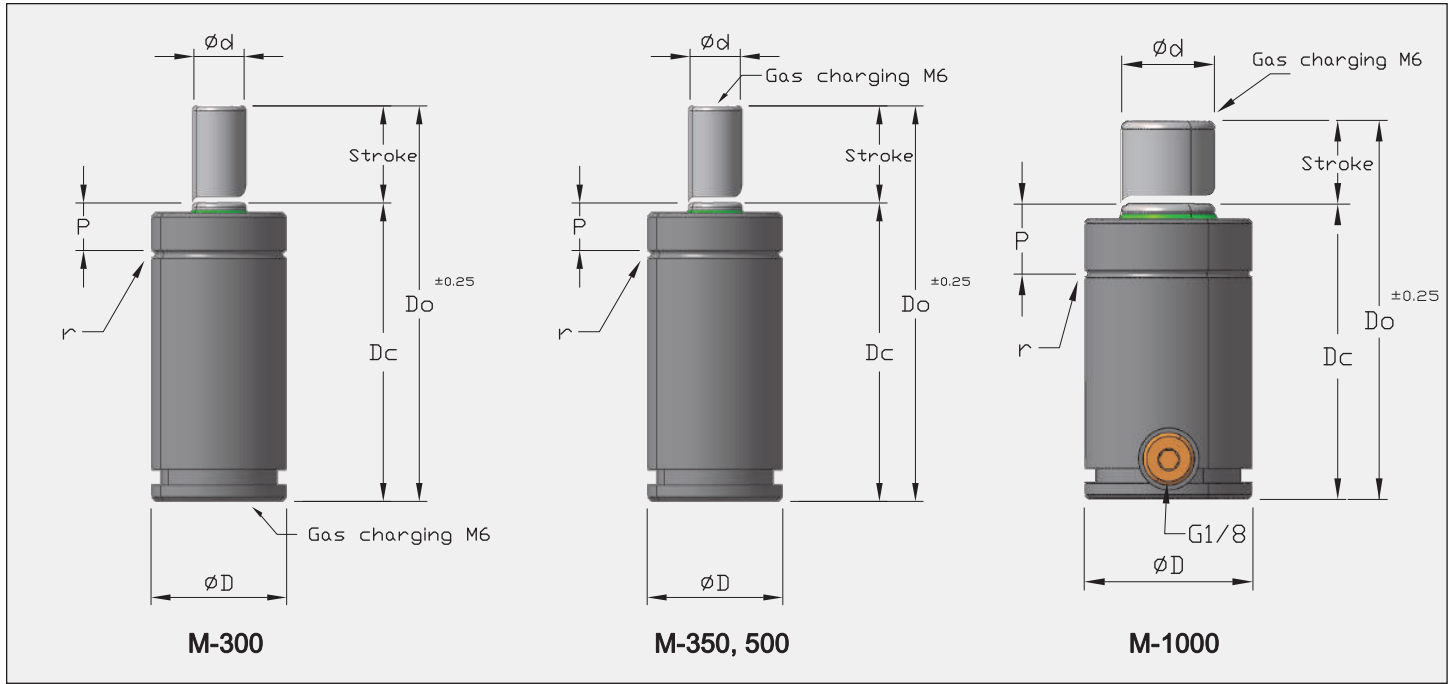

### Important!

Pressure medium: **Nitrogen Gas (N<sub>2</sub>)**  
 Operating temperature: **0 to +80°C**  
 Force increase by temperature: **0,33% / °C**

### The Semi Compact Line (M series)

Every Semi Compact gas spring combines the convenience of a self-contained gas spring with the increased contact force and a shorter body height.

### MODEL COMPARISON - BODY DIAMETER 50mm - STROKE 25mm

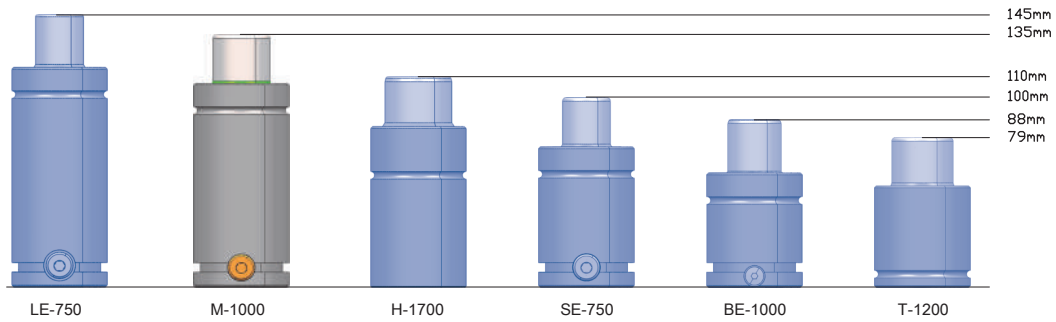





Part N°	Max. stem speed m/s	Max. charging pressure (bar)	Min. charging pressure (bar)	Order No for Spare Parts Kit
M-300	1.0	150	50	Kit M-00300
M-350	0.8	150	35	Kit M-00350
M-500	1.0	150	35	Kit M-00500
M-1000	0.8	150	35	Kit M-01000

Part N°						
M-300	✓	✓	DS / DSC 38	DP 38	—	—
M-350	✓	✓	DS 32	DP 32	—	—
M-500	✓	✓	DS / DSC 38	DP 38	—	—
M-1000	✓	✓	DS / DSC 50	DP 50	DB 50	DI 50

Flange Details: See pages 50-56

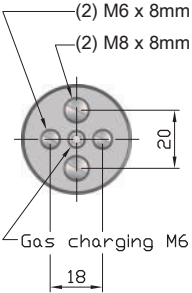
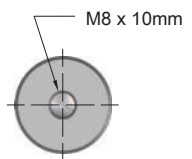
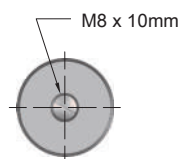
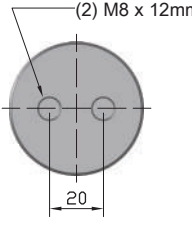

Part N° Model x stroke (mm)	Do mm	Dc mm	ØD mm	Ød mm	P mm	r mm	 bar	 daN	 daN	 Kg		Cylinder bases
<b>M-300 x 10</b>	70	60	38	15	12,5	1	142	250	330	0,43	-	
13	75,4	62,7							340	0,44		
16	82	66							355	0,46		
25	100	75							370	0,51		
38	126	88							375	0,59		
50	150	100							385	0,66		
63	177	114							390	0,73		
80	210	130							400	0,83		
100	250	150							410	0,96		
125	300	175							415	1,05		
<b>M-350 x 10</b>	70	60	32	18	12,5	1	138	350	465	0,28	-	
15	80	65							475	0,30		
25	100	75							500	0,32		
38	126	88							545	0,36		
50	150	100							565	0,40		
63	176	113							595	0,44		
80	210	130							600	0,50		
<b>M-500 x 10</b>	75	65	38	22	11,5	1	132	500	610	0,38	-	
12	79	67							650	0,40		
15	85	70							685	0,43		
25	105	80							710	0,45		
38	131	93							735	0,52		
50	155	105							775	0,55		
63	186	123							795	0,62		
80	220	140							815	0,69		
<b>M-1000 x 25</b>	135	110	50	30	15,5	2	142	1000	1385	1,20	✓	
38	161	123							1465	1,35		
50	185	135							1515	1,46		
63	211	148							1560	1,52		
80	245	165			1610				1,73	17,5		
100	295	195			1670				2,41			
125	345	220			1695				3,10			
160	415	255			1735				3,45			

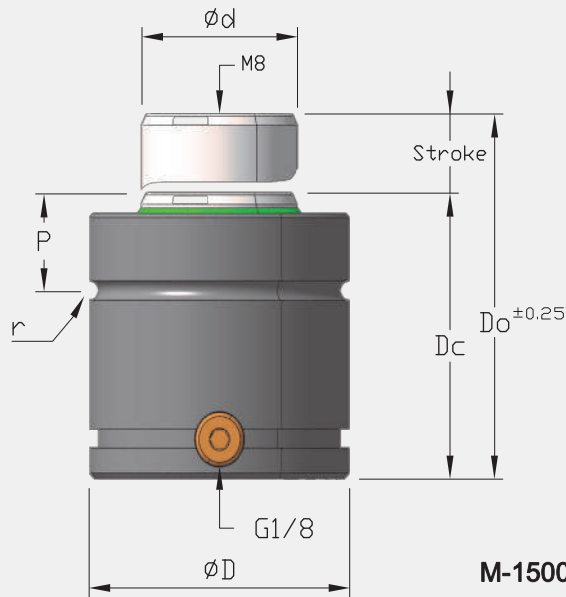

**M-1500, 2500, 3000, 4000, 6500**

**Important!**

Pressure medium: **Nitrogen Gas (N<sub>2</sub>)**  
 Operating temperature: **0 to +80°C**  
 Force increase by temperature: **0,33% / °C**

## The Semi Compact Line (M series)

Every Semi Compact gas spring combines the convenience of a self-contained gas spring with the increased contact force and a shorter body height.

### MODEL COMPARISON - BODY DIAMETER 50mm - STROKE 25mm

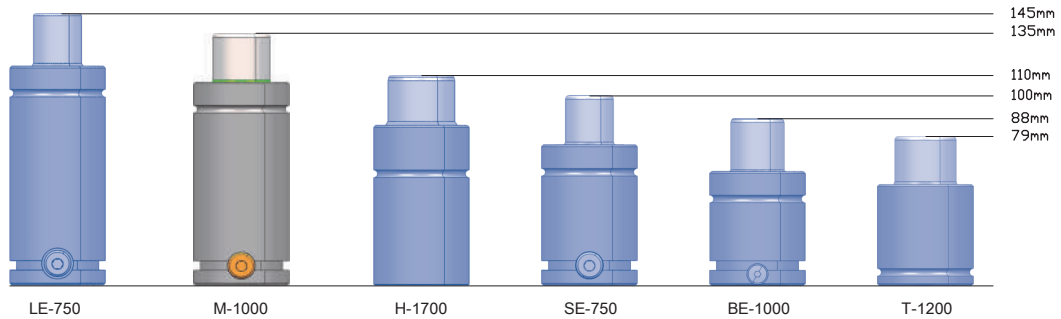

Part N°	Max. stem speed m/s	Max. charging pressure (bar)	Min. charging pressure (bar)	Order No for Spare Parts Kit
M-1500	1.0	150	35	Kit M-01500
M-2500	0.8	155	35	Kit M-02500
M-3000	0.5	150	35	Kit M-03000
M-4000	0.5	150	35	Kit M-04000
M-6500	0.6	150	35	Kit M-06500

Part N°						
M-1500	✓	✓	DS / DSC 63	DP 63	DB 63	—
M-2500	✓	✓	DS / DSC 75	DP 75	DB 75	DI 75
M-3000	✓	✓	DS / DSC 75	DP 75	DB 75	DI 75
M-4000	✓	✓	DS / DSC 95	DP 95	DB 95	DI 95
M-6500	✓	✓	DS / DSC 120	DP 120	DB 120	DI 120

**Flange Details:** See pages 50-56





Part N° Model x stroke (mm)	Do mm	Dc mm	ØD mm	Ød mm	P mm	r mm	bar	daN	daN	Kg		Cylinder bases
<b>M-1500 x 25</b>	135	110	63	36	19	2	148	1500	1990	1,86		<p>(2) M8 x 12mm</p>
<b>38</b>	161	123							2110	2,10		
<b>50</b>	185	135							2195	2,25		
<b>63</b>	211	148							2275	2,30		
<b>80</b>	245	165							2310	2,55		
<b>100</b>	285	185							2560	3,15		
<b>125</b>	345	220							2545	4,06		
<b>160</b>	415	255							2390	5,23		
<b>M-2500 x 25</b>	145	120	75,2	45	19	2,5	155	2500	3095	2,50		<p>(4) M8 x 12mm</p>
<b>38</b>	171	133							3250	3,25		
<b>50</b>	195	145							3340	4,00		
<b>63</b>	221	158							3425	4,40		
<b>80</b>	255	175							3510	5,05		
<b>100</b>	300	200							3605	5,55		
<b>125</b>	350	225							3680	5,98		
<b>M-3000 x 25</b>	145	120	75,2	50	19	2,5	150	3000	3900	2,70		<p>(4) M8 x 10mm</p>
<b>38</b>	171	133							4165	3,30		
<b>50</b>	195	145							4335	4,10		
<b>63</b>	221	158							4490	4,50		
<b>80</b>	255	175							4615	5,10		
<b>100</b>	300	200							4725	5,90		
<b>125</b>	350	225							4845	6,50		
<b>160</b>	425	265							5575	7,40		
<b>200</b>	510	310	5570	7,85								
<b>M-4000 x 25</b>	155	130	95	60	22	2,5	142	4000	5050	4,20		<p>(4) M8 x 12mm</p>
<b>38</b>	181	143			5345				4,90			
<b>50</b>	205	155			5525				5,30			
<b>63</b>	236	173			6710				6,10			
<b>80</b>	270	190			5915				7,20			
<b>100</b>	310	210			6050				7,80			
<b>125</b>	370	245			6205				8,30			
<b>160</b>	440	280			6350				9,50			
<b>M-6500 x 25</b>	165	140	120	75	24,5	2,5	147	6500	7750	9,45		<p>(4) M10 x 11mm</p>
<b>38</b>	191	153			8180				10,05			
<b>50</b>	215	165			8500				10,75			
<b>63</b>	241	178			8745				11,67			
<b>80</b>	275	195			9125				12,28			
<b>100</b>	315	215			9210				13,35			
<b>125</b>	375	250			9595				14,29			

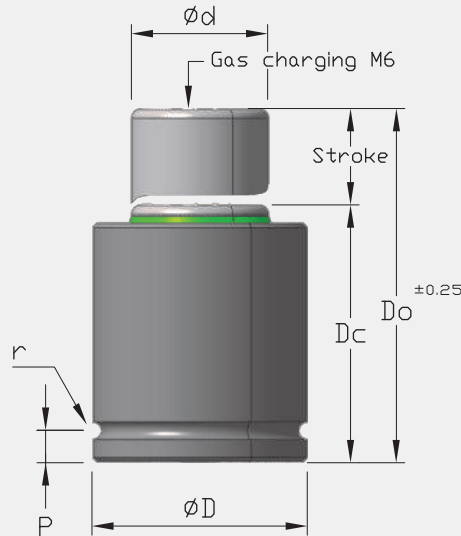

T-500, 750, 1200, 2100, 3000

### Important!

Pressure medium: **Nitrogen Gas (N<sub>2</sub>)**  
 Operating temperature: **0 to +80°C**  
 Force increase by temperature: **0,33% / °C**

### The Super Compact Line (T series)

Every Super Compact gas spring combines the convenience of a self-contained gas spring with the increased on-contact force and shorter body height.

### MODEL COMPARISON - BODY DIAMETER 50mm - STROKE 25mm

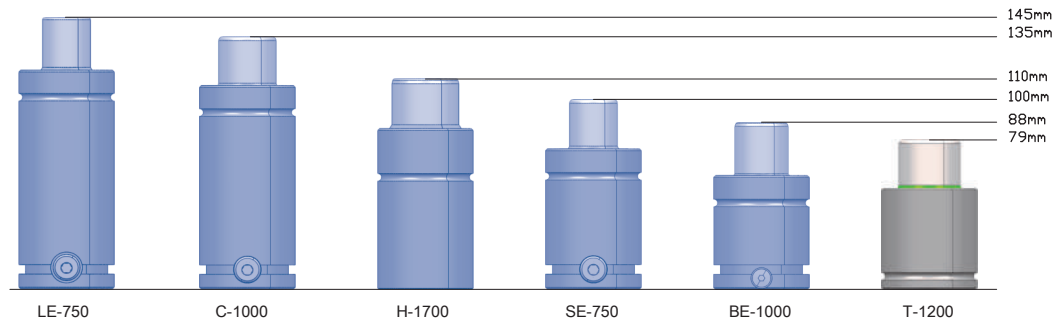





Part N°	Max. stem speed m/s	Max. charging pressure (bar)	Min. charging pressure (bar)	Order No for spare parts kit
T-500	0.5	190	25	Kit T-00500
T-750	0.5	190	25	Kit T-00750
T-1200	0.5	150	50	Kit T-01200
T-2100	0.5	150	50	Kit T-02100
T-3000	0.5	150	50	Kit T-03000

Part N°						
T-500	✓	—	DS 32	—	—	—
T-750	✓	—	DS / DSC 38*	—	—	—
T-1200	✓	✓	DS / DSC 50	—	DB 50	DI 50
T-2100	✓	✓	DS / DSC 63	—	DB 63	—
T-3000	✓	✓	DS / DSC 75*	—	DB 75	DI 75

Flange Details: See pages 50-56

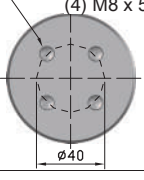

Part N° Model x stroke (mm)	Do mm	Dc mm	ØD mm	Ød mm	P mm	r mm	 bar	 daN	 daN	 Kg		Cylinder bases
T-500 x 12	49	37	32	18	5	1	190	500	840	0,19	—	( NO FIXING HOLES IN THE BOTTOM )
16	58	42							855	0,21		
19	65	46							855	0,22		
25	76	51							865	0,24		
38	102	64							865	0,27		
50	127	77							870	0,30		
63	152	89							875	0,34		
80	186	106							875	0,41		
T-750 x 16	58	42	38	22	5	1	190	750	1180	0,27	—	( NO FIXING HOLES IN THE BOTTOM )
19	65	46							1185	0,30		
25	78	53							1195	0,32		
38	102	64							1205	0,35		
50	127	77							1210	0,39		
63	152	89							1215	0,42		
80	186	106							1225	0,51		
T-1200 x 13 [11.5]	55	41,5							50,2	32		
19 [17]	67	47,5	2090	0,52								
25 [22.5]	79	53,5	2075	0,59								
38 [34]	105	66,5	2050	0,68								
50 [45]	129	78,5	2045	0,79								
63 [57]	155	91,5	2045	0,95								
80 [72]	189	108,5	2040	1,10								
T-2100 x 13 [11.5]	60	46,5	63,2	42	8,3	2	150	2100			3925	0,87
25 [22.5]	84	58,5							3895	0,92		
38 [34]	110	71,5							3885	1,30		
50 [45]	134	83,5							3885	1,55		
63 [57]	160	96,5							3880	1,70		
80 [72]	194	113,5							3875	1,85		
T-3000 x 12 [11]	61	48	75,2	50	8,3	2,5	150	3000	5680	1,25	—	 (4) M8 x 5mm
25 [22.5]	87	61							5610	1,39		
38 [34]	113	74							5590	1,62		
50 [45]	137	86							5580	1,72		
63 [57]	163	99							5580	1,99		
80 [72]	197	116							5575	2,18		
*Actual stroke shown in brackets above												

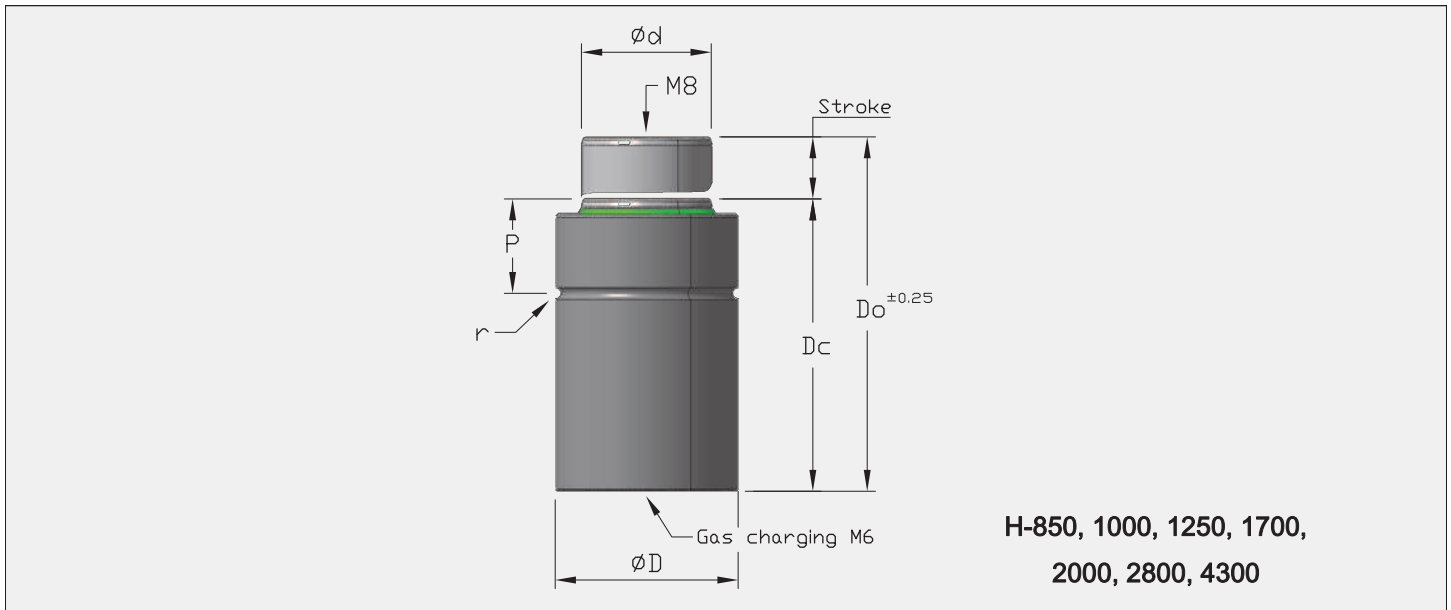

### Important!

Pressure medium: **Nitrogen Gas (N<sub>2</sub>)**  
 Operating temperature: **0 to +80°C**  
 Force increase by temperature: **0,33% / °C**

### The Maximum Force Line (H series)

Every Maximum Force gas spring provides the maximum force in a self-contained gas spring with the increased on-contact force of a bore seal cylinder.

### MODEL COMPARISON - BODY DIAMETER 50mm - STROKE 25mm

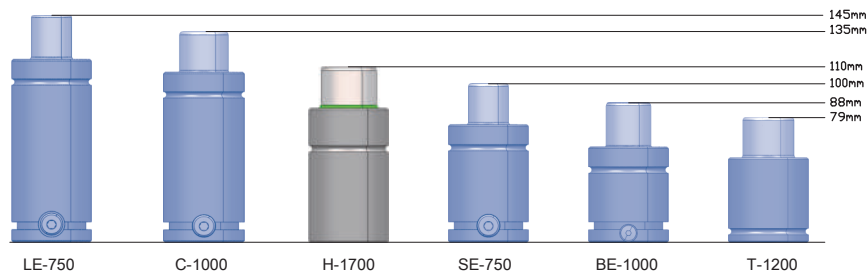

Part N°	Max. stem speed m/min	Max. charging pressure (bar)	Min. charging pressure (bar)	Order No for spare parts kit
H-850	20	175	35	Kit H-00850
H-1000	15	185	35	Kit H-01000
H-1250	20	175	35	Kit H-01250
H-1700	20	175	35	Kit H-01700
H-2000	15	185	35	Kit H-02000
H-2800	20	175	35	Kit H-02800
H-4300	20	175	35	Kit H-04300

Part N°						
H-850	✓	✓	DS / DSC 38	—	—	—
H-1000	✓	✓	DS / DSC 38	—	—	—
H-1250	✓	✓	DS / DSC 45	—	—	DI 45
H-1700	✓	✓	DS / DSC 50	—	DB 50	DI 50
H-2000	✓	✓	DS / DSC 50	—	DB 50	DI 50
H-2800	✓	✓	DS / DSC 63	—	DB 63	—
H-4300	✓	✓	DS / DSC 75	—	DB 75	DI 75

Flange Details: See pages 50-56



Part N° Model x stroke (mm)	Do mm	Dc mm	ØD mm	Ød mm	P mm	r mm	bar	daN	daN	Kg		Cylinder bases
<b>H-850 x 12</b>	74	62	38	25	21,5	1	175	850	1280	0,40	—	
<b>25</b>	100	75							1435	0,45		
<b>38</b>	130	92							1450	0,52		
<b>50</b>	155	105							1485	0,64		
<b>63</b>	185	122							1480	0,75		
<b>80</b>	225	145							1475	0,86		
<b>H-1000 x 25</b>	105	80	38	25	21,5	1	185	1000	1570	0,50	—	
<b>38</b>	135	97							1600	0,57		
<b>50</b>	160	110							1675	0,69		
<b>63</b>	205	142							1540	0,80		
<b>80</b>	240	160							1600	0,91		
<b>H-1250 x 12</b>	79	67	45	30	23,5	1	175	1250	1800	0,62	—	
<b>25</b>	105	80							2050	0,75		
<b>38</b>	135	97							2120	0,83		
<b>50</b>	160	110							2150	0,91		
<b>63</b>	190	127							2195	1,10		
<b>80</b>	230	150							2120	1,17		
<b>H-1700 x 12</b>	84	72	50	35	26,5	2	175	1700	2485	0,82	—	
<b>25</b>	110	85							2800	0,91		
<b>38</b>	140	102							2895	1,12		
<b>50</b>	165	115							2960	1,25		
<b>63</b>	195	132							2975	1,35		
<b>80</b>	235	155							2970	1,48		
<b>H-2000 x 25</b>	135	110	50	35	26,5	2	185	1925	2610	1,02	—	
<b>38</b>	165	127							2780	1,32		
<b>50</b>	190	140							2910	1,45		
<b>63</b>	220	157							2995	1,55		
<b>80</b>	255	175							3120	1,68		
<b>H-2800 x 12</b>	94	82	63,2	45	28	2	175	2800	3825	1,31	—	
<b>25</b>	120	95							4410	1,52		
<b>38</b>	150	112							4595	1,85		
<b>50</b>	175	125							4630	1,97		
<b>63</b>	210	147							4695	2,05		
<b>80</b>	250	170							4740	2,22		
<b>H-4300 x 12</b>	94	82	75,2	56	29	2,5	175	4300	5910	1,82	—	
<b>25</b>	120	95							6795	2,10		
<b>38</b>	150	112							7095	2,42		
<b>50</b>	175	125							7365	2,61		
<b>63</b>	210	147							7270	2,70		
<b>80</b>	250	170							7345	3,05		

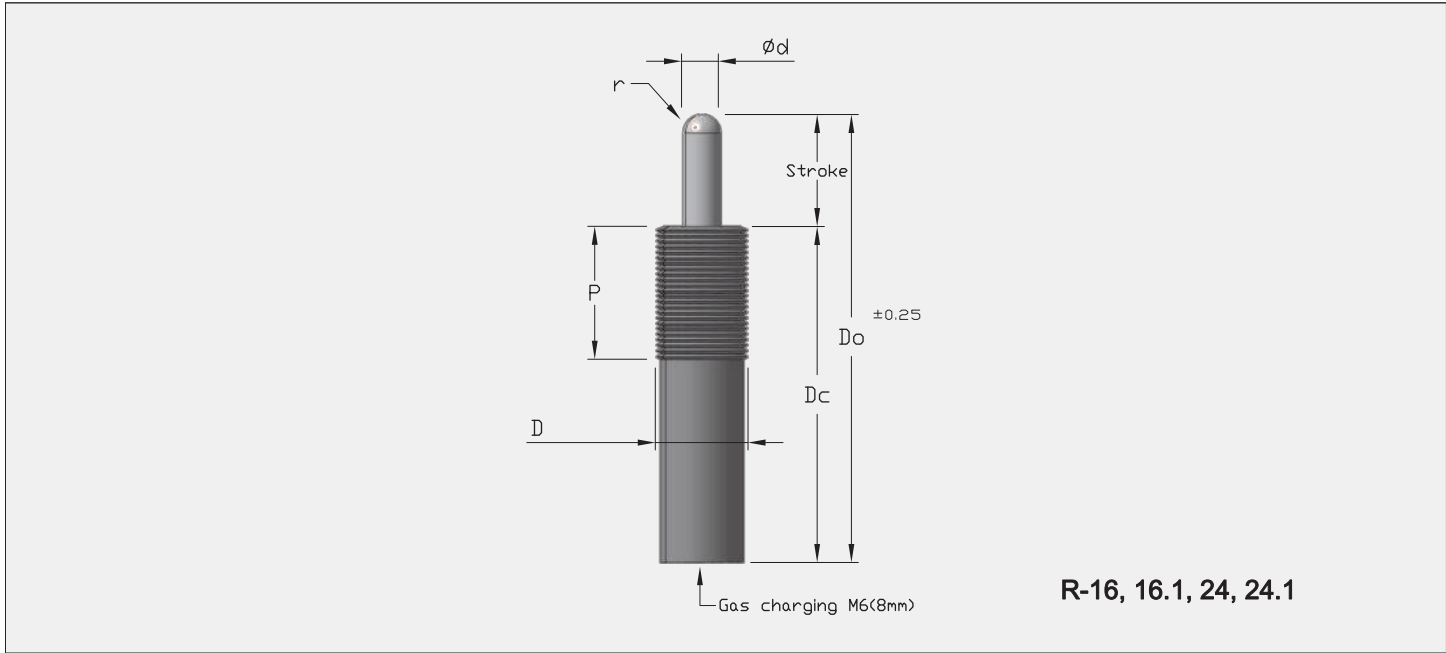

**Important!**

Pressure medium: **Nitrogen Gas (N<sub>2</sub>)**  
 Operating temperature: **0 to +80°C**  
 Force increase by temperature: **0,33% / °C**

**The Threaded Line (R series)**

Every threaded gas spring provides design flexibility.

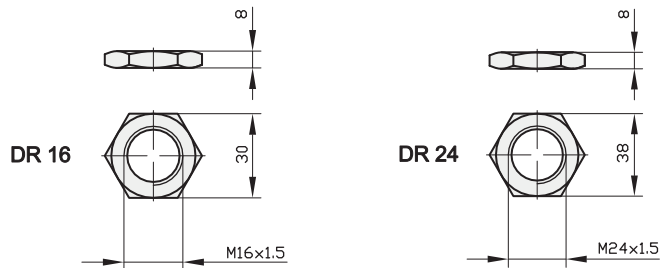

Part N°	Max. stem speed m/s	Max. charging pressure (bar)	Min. charging pressure (bar)	Order No for spare parts kit
R-16	0.5	175	35	Kit R-16
R-16.1	0.5	175	35	Kit R-16
R-24	0.5	175	25	Kit R-24
R-24.1	0.5	175	25	Kit R-24





Part N°		
R-16	✓	DR 16
R-16.1	✓	DR 16
R-24	✓	DR 24
R-24.1	✓	DR 24



Here's how to order the KEY  
**R16KEY**, for R-16 & R-16.1 model  
**R24KEY**, for R-24 & R-24.1 model

**Flange Details:** See pages 50-56



Part N° Model x stroke (mm)	Do mm	Dc mm	ØD mm	Ød mm	P mm	r mm	 bar	 daN	 daN	 Kg		Cylinder bases
<b>R-16 x 10</b>	80	70	M16x1,5	6	35	3	35	10	≈ 12	0,07	—	( NO MOUNTING HOLES IN BOTTOM )
<b>20</b>	100	80					50	15	≈ 15	0,08		
<b>30</b>	120	90					70	20	≈ 25	0,09		
<b>40</b>	140	100					90	25	≈ 30	0,15		
<b>50</b>	160	110					110	30	≈ 35	0,20		
<b>60</b>	180	120					125	35	≈ 45	0,22		
<b>70</b>	200	130					140	40	≈ 50	0,25		
<b>80</b>	220	140					160	45	≈ 55	0,27		
<b>100</b>	260	160					175	50	≈ 60	0,28		
<b>R-16.1 x 10</b>	65	55					M16x1,5	6	35	3		
<b>20</b>	85	65	50	15	≈ 18	0,07						
<b>30</b>	105	75	70	20	≈ 25	0,08						
<b>40</b>	125	85	90	25	≈ 32	0,10						
<b>50</b>	145	95	110	30	≈ 40	0,15						
<b>60</b>	165	105	125	35	≈ 45	0,18						
<b>70</b>	185	115	140	40	≈ 50	0,20						
<b>80</b>	205	125	160	45	≈ 55	0,21						
<b>100</b>	245	145	175	50	≈ 60	0,23						
<b>R-24 x 10</b>	80	70	M24x1,5	10	40	5					25	20
<b>20</b>	100	80					50	40	≈ 50	0,22		
<b>30</b>	120	90					75	60	≈ 75	0,24		
<b>40</b>	140	100					90	80	≈ 100	0,25		
<b>50</b>	160	110					100	80	≈ 100	0,27		
<b>60</b>	180	120					125	100	≈ 125	0,30		
<b>70</b>	200	130					150	120	≈ 150	0,35		
<b>80</b>	220	140					175	140	≈ 175	0,41		
<b>100</b>	260	160					175	140	≈ 175	0,45		
<b>R-24.1 x 10</b>	65	55					M24x1,5	10	40	5	25	20
<b>20</b>	85	65	50	40	≈ 55	0,20						
<b>30</b>	105	75	75	60	≈ 80	0,22						
<b>40</b>	125	85	90	80	≈ 105	0,23						
<b>50</b>	145	95	100	80	≈ 105	0,25						
<b>60</b>	165	105	125	100	≈ 135	0,28						
<b>70</b>	185	115	150	120	≈ 160	0,32						
<b>80</b>	205	125	175	140	≈ 185	0,38						
<b>100</b>	245	145	175	140	≈ 185	0,42						

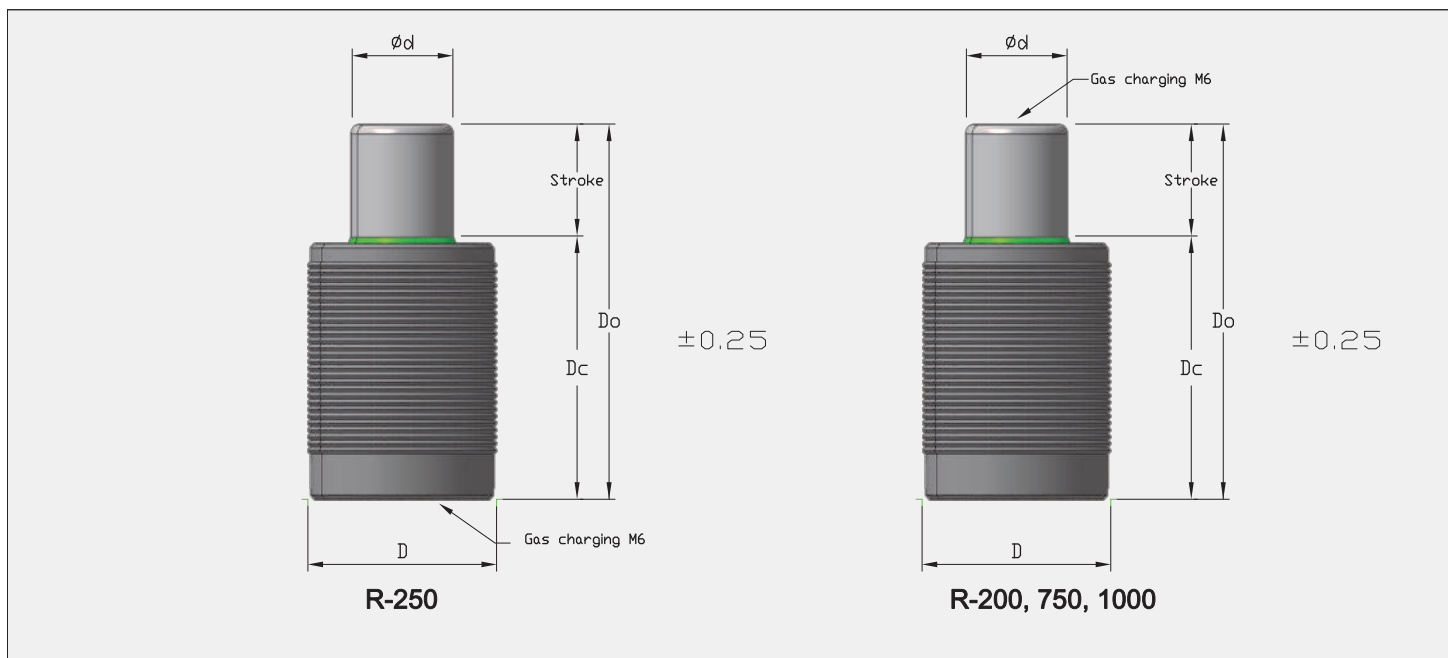

### Important!

Pressure medium: **Nitrogen Gas (N<sub>2</sub>)**  
 Operating temperature: **0 to +80°C**  
 Force increase by temperature: **0,33% / °C**

### The Threaded Line (R series)

Every threaded gas spring provides design flexibility.

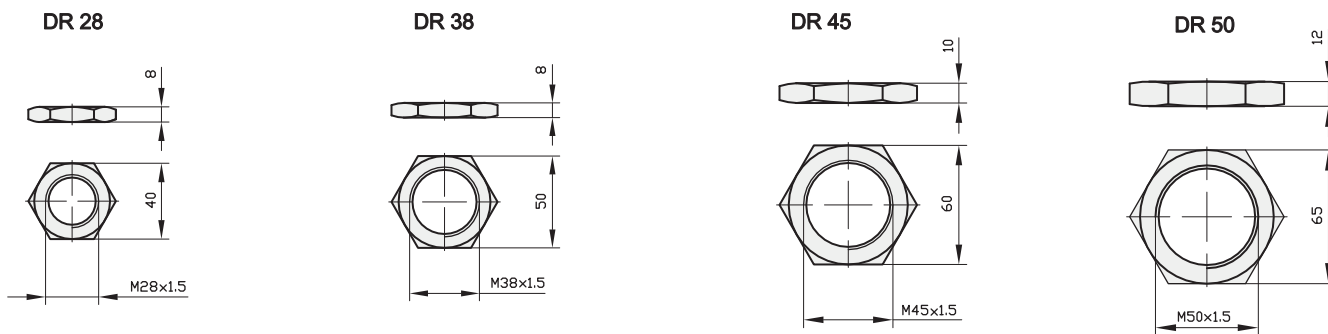

Part N°	Max. stem speed m/s	Max. charging pressure (bar)	Min. charging pressure (bar)	Order No for spare parts kits
R-200	0.6	175	25	Kit R-200
R-250	0.8	150	50	Kit R-250
R-750	0.8	150	35	Kit R-750
R-1000	0.8	150	35	Kit R-1000

Part N°		
R-200	DR 28	DR 28
R-250	DR 38	DR 38
R-750	DR 45	DR 45
R-1000	DR 50	DR 50

Flange Details: See pages 50-56





## Clamping Slot Details



SERIES	A	B
<b>B SERIES</b>		
350	4	3.5
500	4	4.0
750	4	4.0
1000	8	7.0
1500	8	7.0
2400	8	7.0
4200	8	7.0
6600	8	7.0
<b>P SERIES</b>		
750	4	3.5
1000	8	7.0
<b>PE SERIES</b>		
750	4	4
1000	8	5
<b>S SERIES</b>		
500	4	3.5
750	8	7.0
1500	8	7.0
<b>SE SERIES</b>		
500	4	4
750	8	5
1500	8	5
3000	8	5
<b>L SERIES</b>		
500	4	3.5
750	8	7.0
1500	8	7.0
3000	8	7.0
5000	8	7.0
<b>LE SERIES</b>		
500	4	4
750	8	5
1500	8	5
3000	8	5
5000	8	5
7500	8	8
10000	8	8
<b>M SERIES</b>		
300	4	4
350	4	3.5
500	4	3.5
1000	8	5
1500	8	5
2500	8	5
3000	8	5
4000	8	5
6500	8	5

FLANGE DS

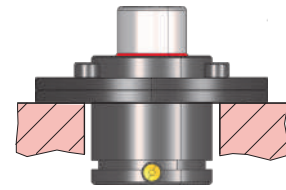

DS 19

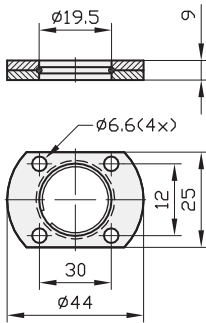

DS 25

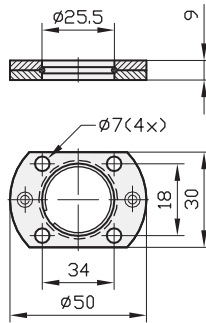

DS 25/1

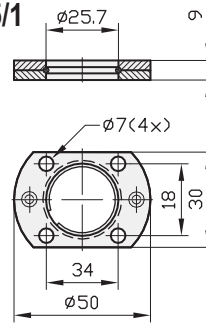

DS 32

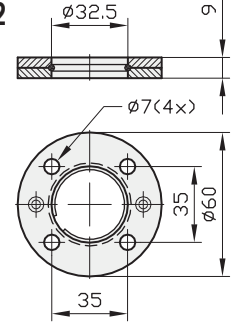

DS 32/1

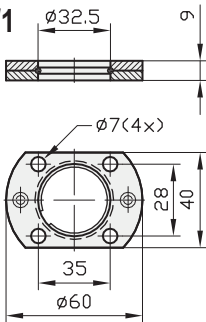

DS 38

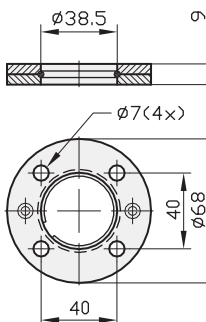

DS 45

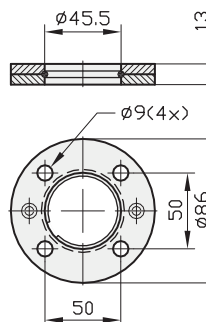

DS 50

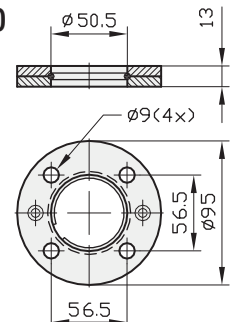

DS 63

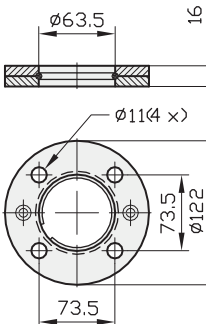

DS 75

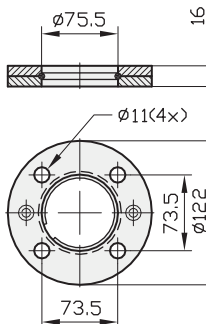

DS 95

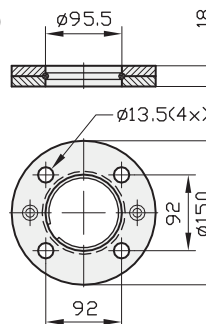

DS 120

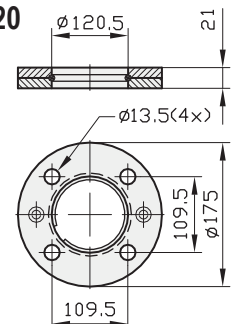

DS 150

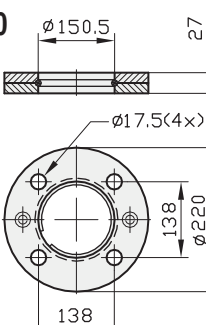

## FLANGE DSC

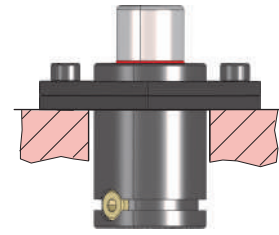

**DSC 38**

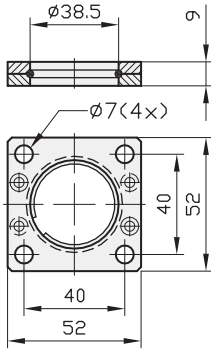

**DSC 45**

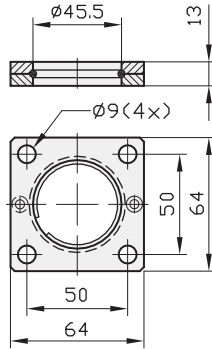

**DSC 50**

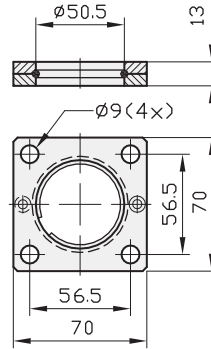

**DSC 63**

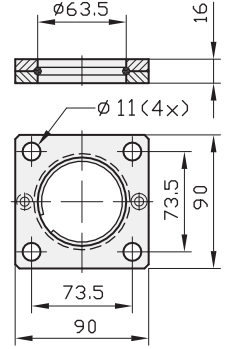

**DSC 75**

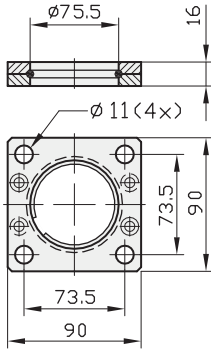

**DSC 95**

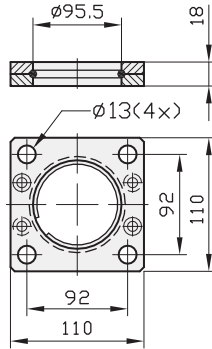

**DSC 120**

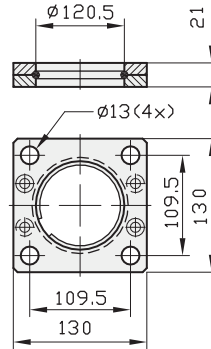

**DSC 150**

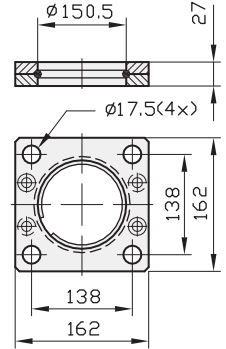

**DSC 195**

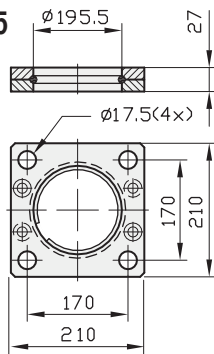

FLANGE DP

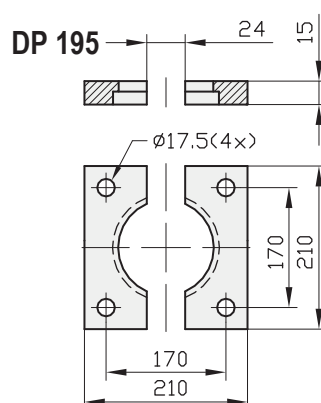
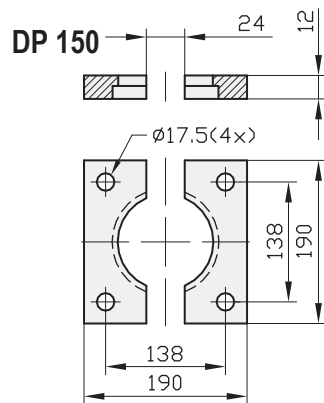
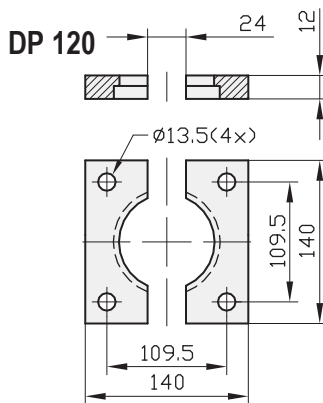
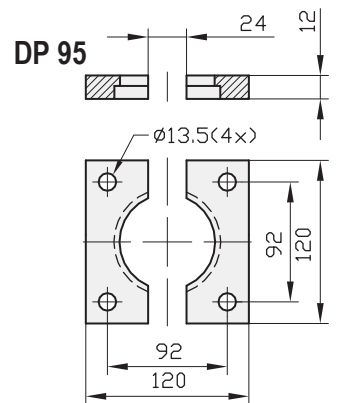
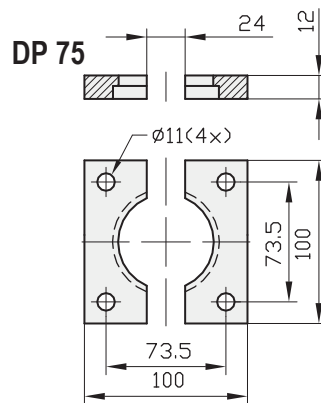
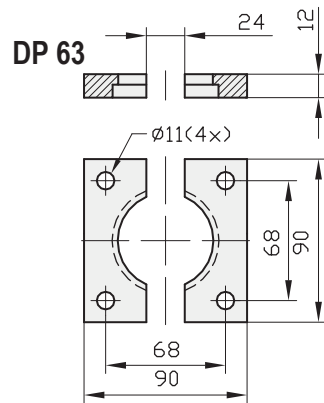
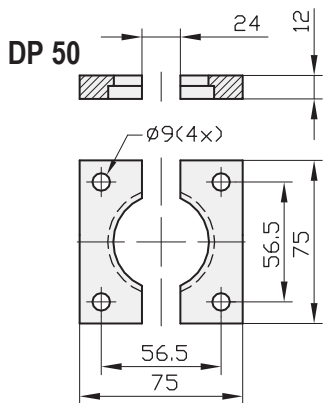
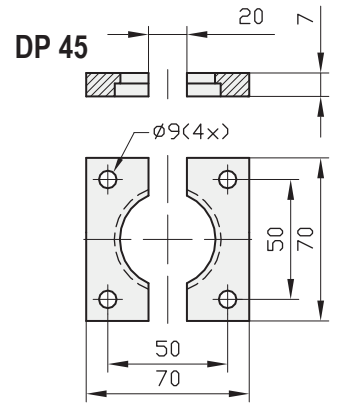
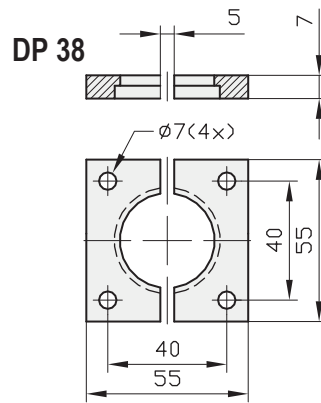
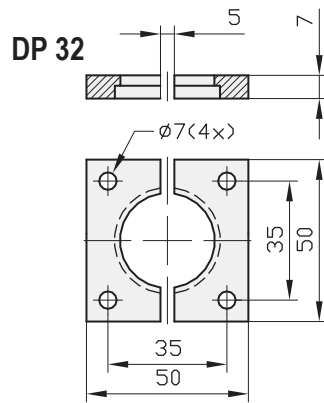
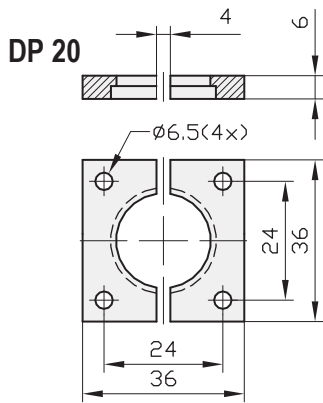

## FLANGE DB

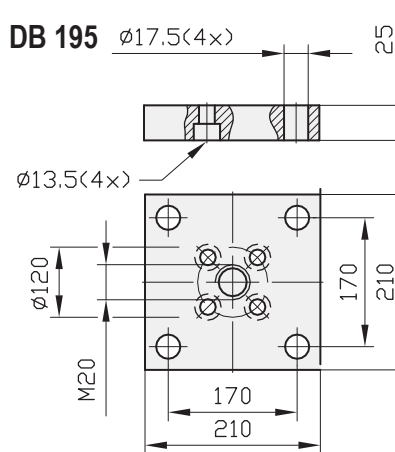
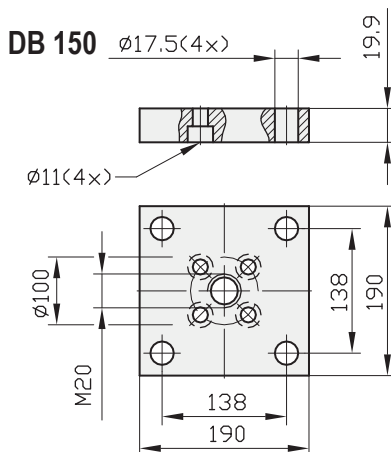
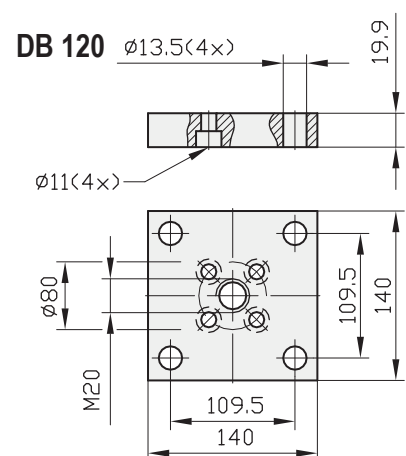
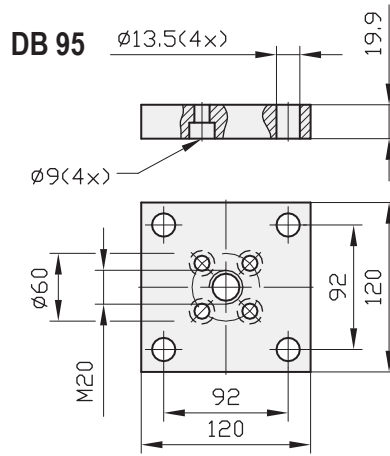
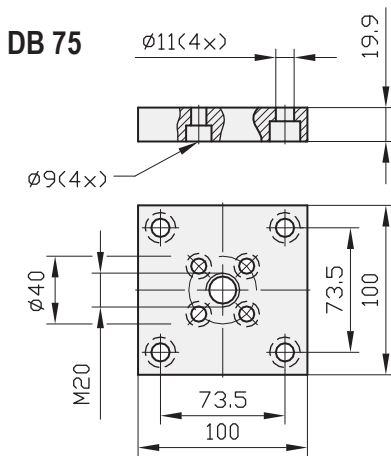
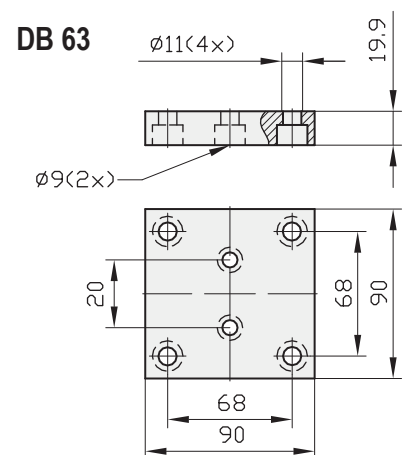
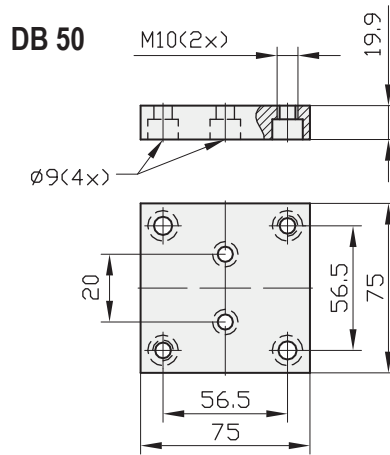
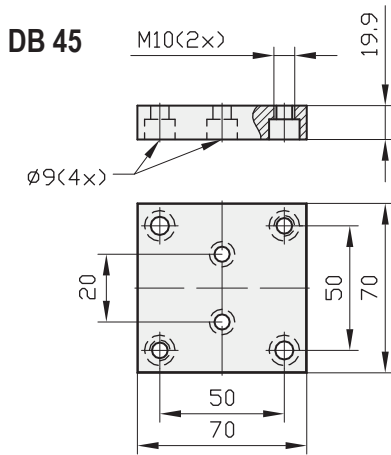
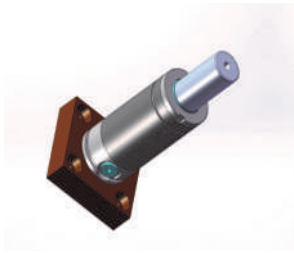

FLANGE DI

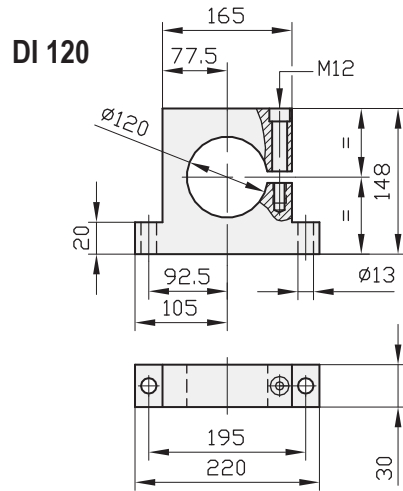
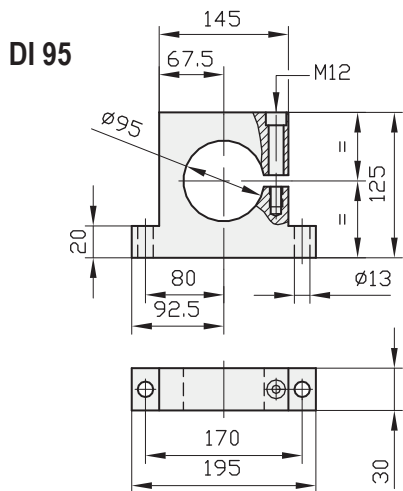
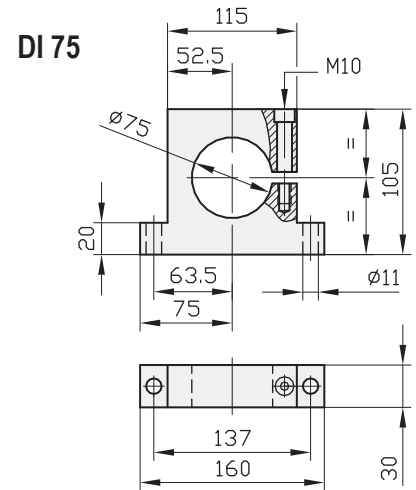
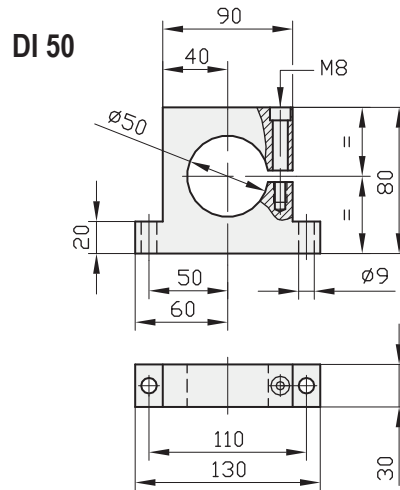
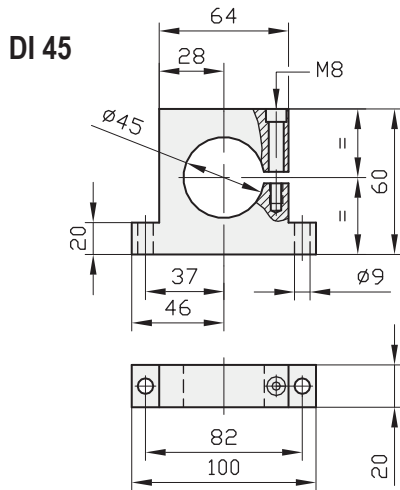
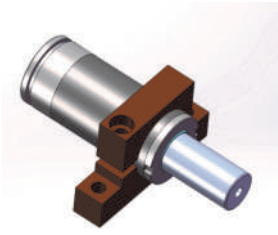

## FLANGE DRS

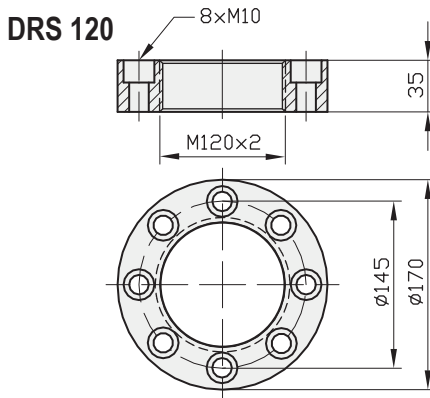
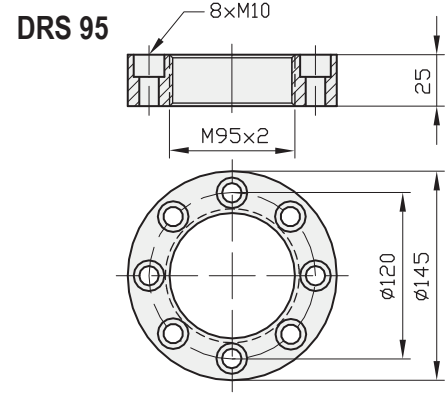
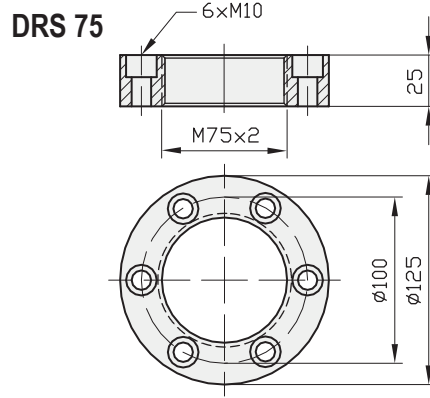
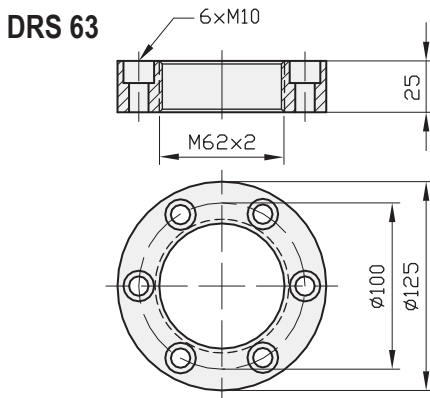
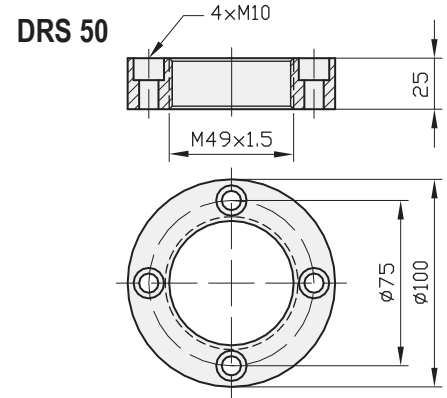
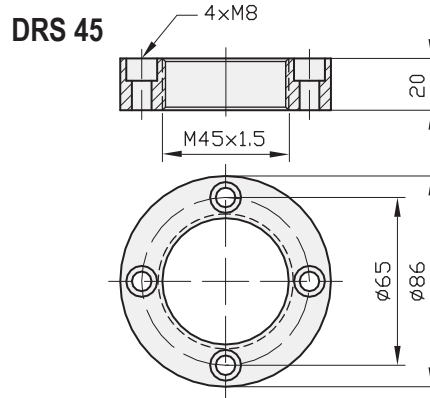
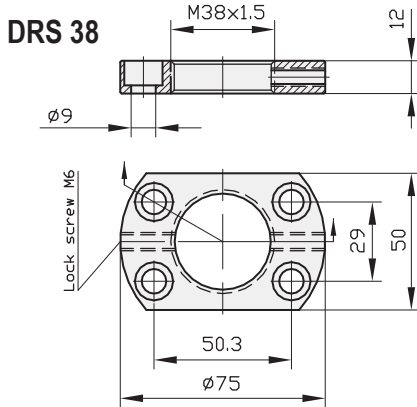
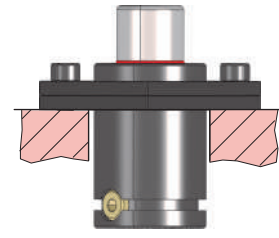
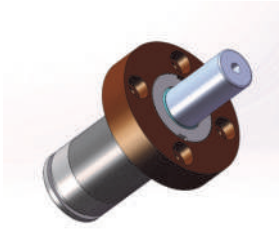





**FITTING RMF-D1**

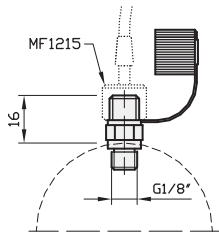

**FITTING RMF-D2**

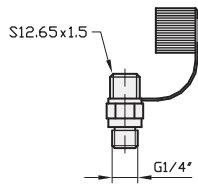

**FITTING RMF-D3**

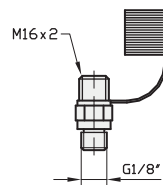

**FITTING RMF-D4**

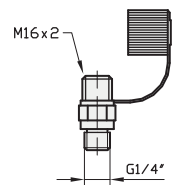

**FITTING RMF-C**

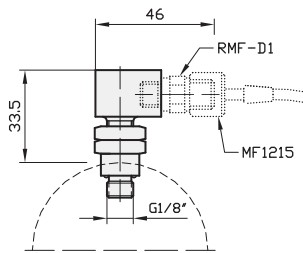

**FITTING RMF-T**

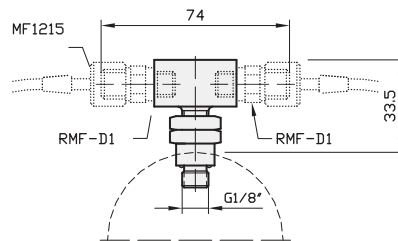

**FITTING RMF-L**

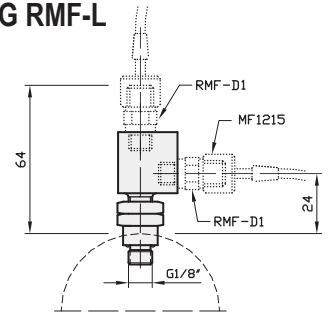

**FITTING RMF-M**

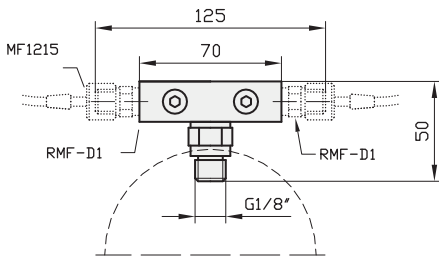

**How to order**

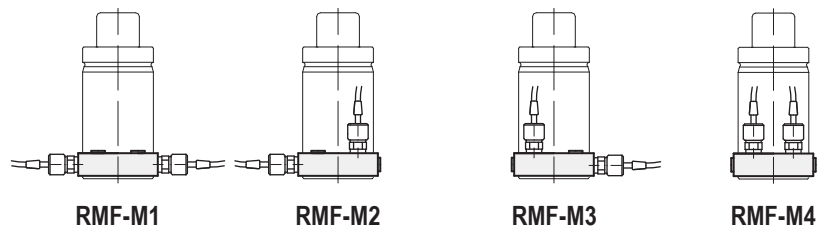

**FITTING RMF-R**

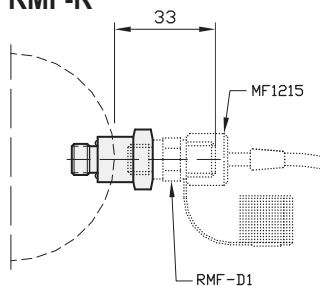

**Models:**

P & PE 1000, S & SE 750, B & BE 2400

**FITTING RMF-FH**

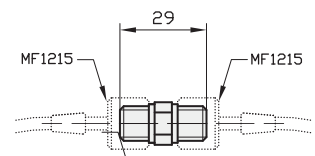

**PLUG M6-1**

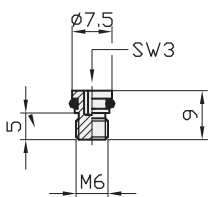

**PLUG M6-2**

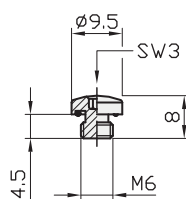

**PLUG G1/8**

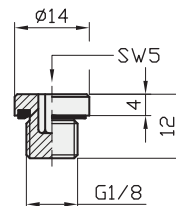

**PLUG G1/4**

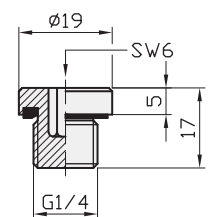

FILLING VALVE TPFV1



FILLING VALVE TPFV2



FILLING VALVE TPFV3



FILLING VALVE TPFV4



THRUST PLATE TPSC-M6

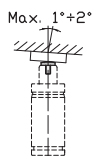
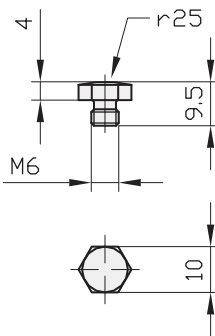

THRUST PLATE TPSC-M6OR

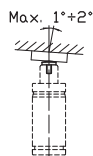
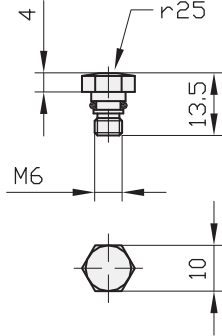

THRUST PLATE TPSC-M8L

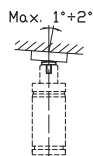
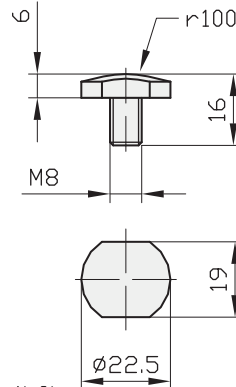

THRUST PLATE TPSC-M8C

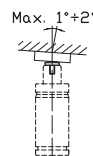
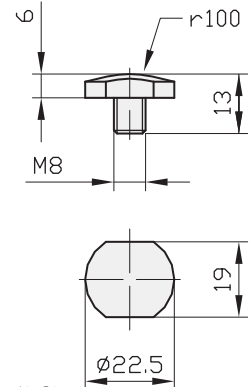

MULTIPLE CONTROL PANEL PM101

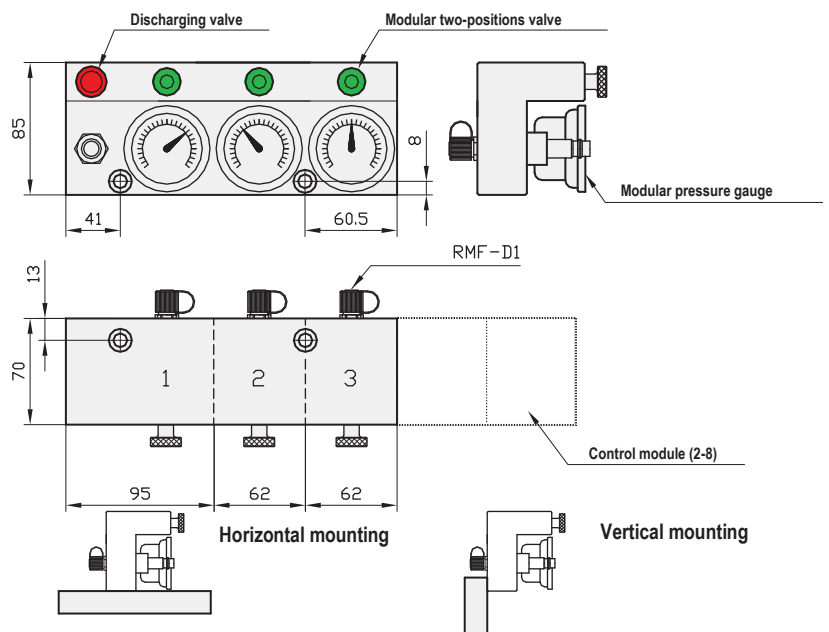
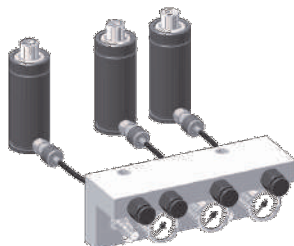
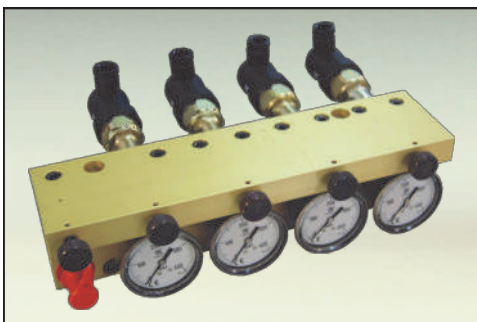

How to order

Reference control panel - number of units

Example: PM101 - 3

This is the PM101 modular multiple control panel, for controlling nitrogen systems. Each module individually controls each gas spring or gas-spring system, making individual or group charging or discharging possible.

CHARACTERISTICS: each module has a G1/8 outlet for interconnection. The control panel can be assembled on its lower base or on its back. Each model has pressure gauge with a range from 0 to 400 Bar.

## MINI CONTROL PANEL P110

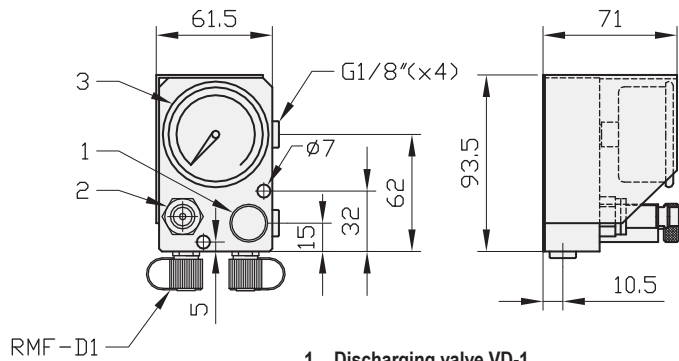
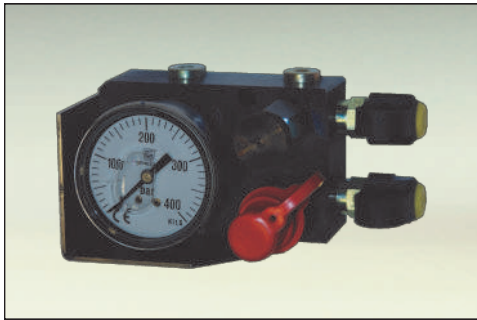

1. Discharging valve VD-1
2. Quick coupling for charging ERM
3. Pressure gauge MP-1

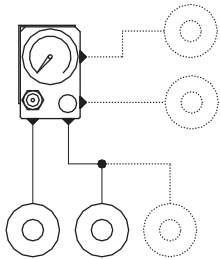

Max. 4 connectors

*Mini-control panel: this small-sized device is used for the permanent control of gas-spring pressure. It is equipped with a quick-fit socket for gas charging and a discharging valve for decompression. P110 control panels have up to 4 G1/8" outlets for a gas spring interconnection. Pressure gauge range is from 0 to 400 Bar.*

## CONTROL PANEL P100

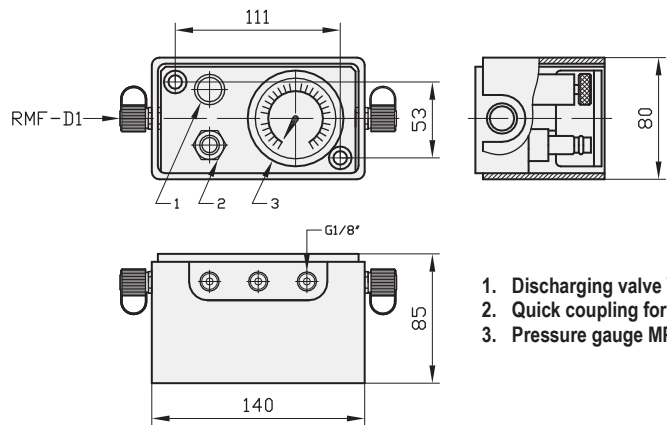

1. Discharging valve VD-1
2. Quick coupling for charging ERM
3. Pressure gauge MP-1

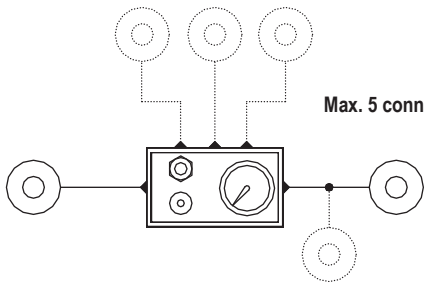

Max. 5 connectors

*Standard control panel. This device is used for permanently controlling gas spring pressure. It is equipped with a quick-fit socket and discharging valve for decompression. The P100 control panel has up to 5 G1/8" outlets for interconnecting gas springs. Pressure gauge range is from 0 to 400 Bar.*

FLEXIBLE HOSE MF1215-RR



**MF1215-RR** - **L**  
 Model Length

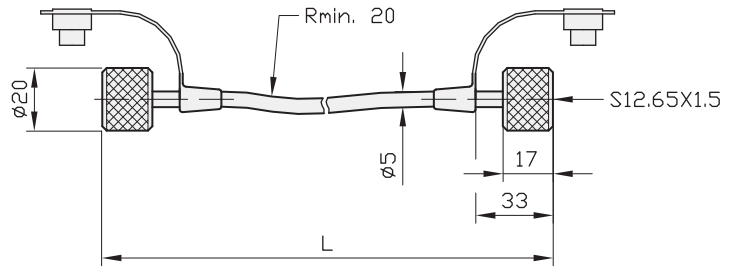

FLEXIBLE HOSE MF1215-RC



**MF1215-RC** - **L**  
 Model Length

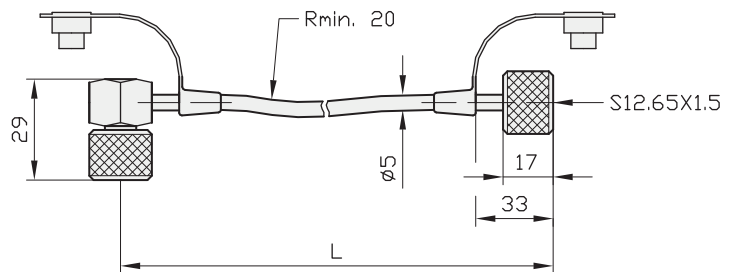

FLEXIBLE HOSE MF1215-CC



**MF1215-CC** - **L**  
 Model Length

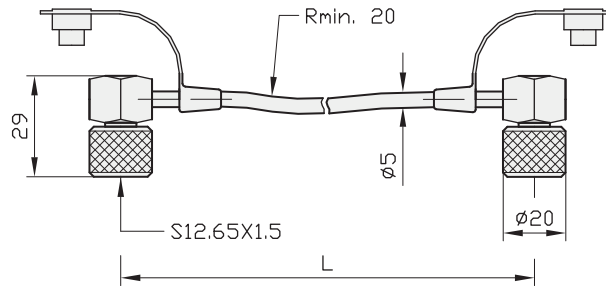

FLANGE FOR HOSE FIXTURE  
 BL-1

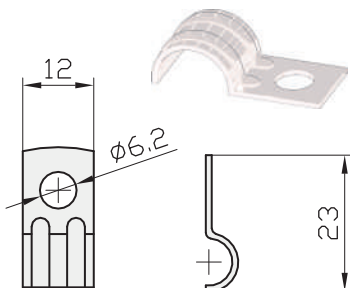

FLANGE FOR HOSE FIXTURE  
 BL-2



## HOSE INSTALLATION GUIDELINES

In order to avoid pressure losses during the interconnected gas spring connection process, the two ends of the hose must be screwed in simultaneously.

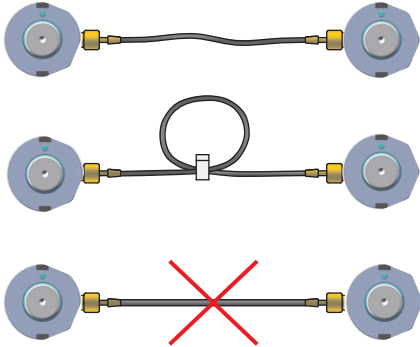

Hose length should be a little more than the exact length (10 or 20% more).

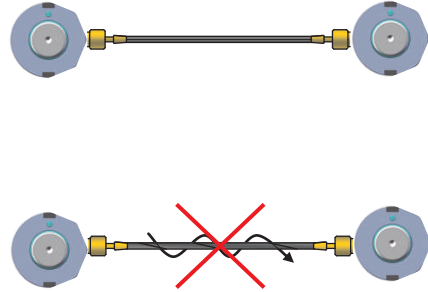

The hose must not be twisted during the installation process.

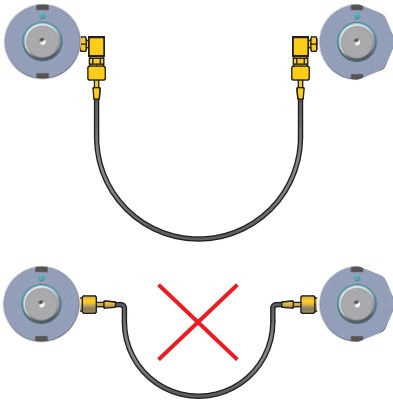

Avoid sharp bends in the hose.

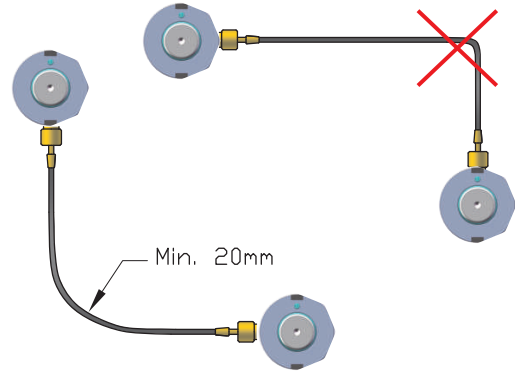

During the installation the minimum curve radius should be respected, 20mm.

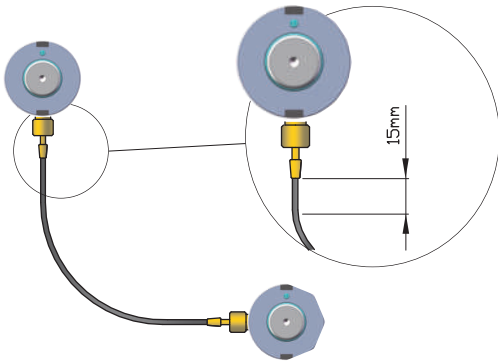

To avoid damage in the connection, the hose should extend in a straight line for at least 15 mm.

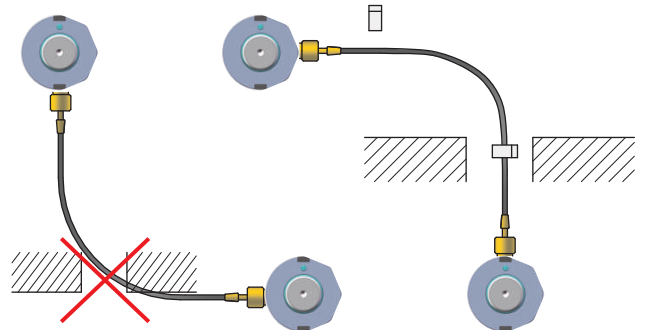

To avoid mechanical damage due to vibration, the hose should be secured using either BL1 or BL2 flanges. (See page 61)

PRESSURE GAUGE MP-1

PRESSURE GAUGE MP-2

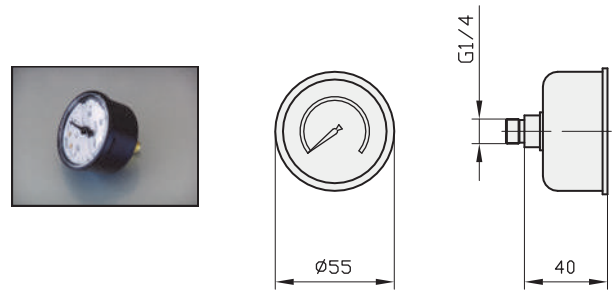
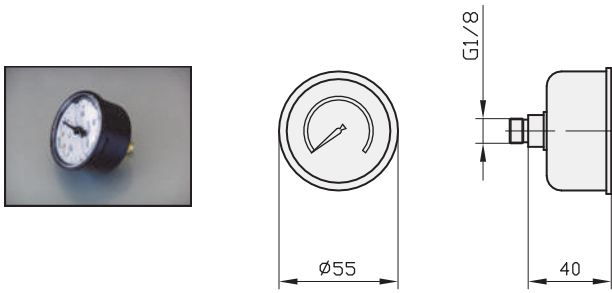

Pressure range: 0-400 Bar

Pressure range: 0-400 Bar

PRESSURE SWITCH

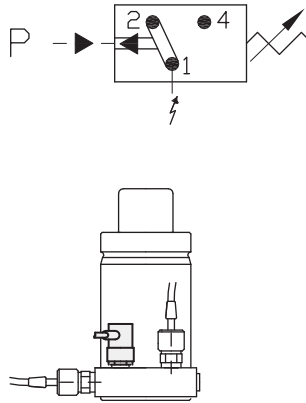
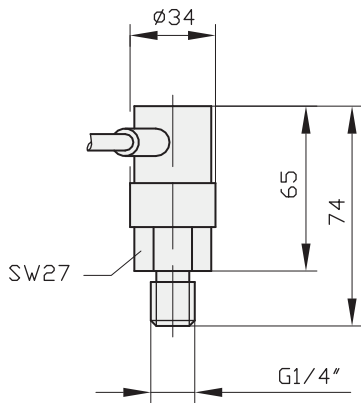

Technical data:  
 Working pressure: 50-200 Bar  
 Working temperature: -30°C - 100°C  
 Operation Voltage: 4A / 250V  
 Operating frequency: < 200 min<sup>-1</sup>

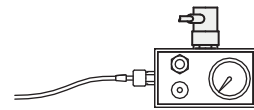

ERM

ERH

VD-1



MALE QUICK-COUPLING FOR CHARGING

FEMALE QUICK-COUPLING FOR CHARGING

DISCHARGING VALVE

UC-101 CONTROL UNIT

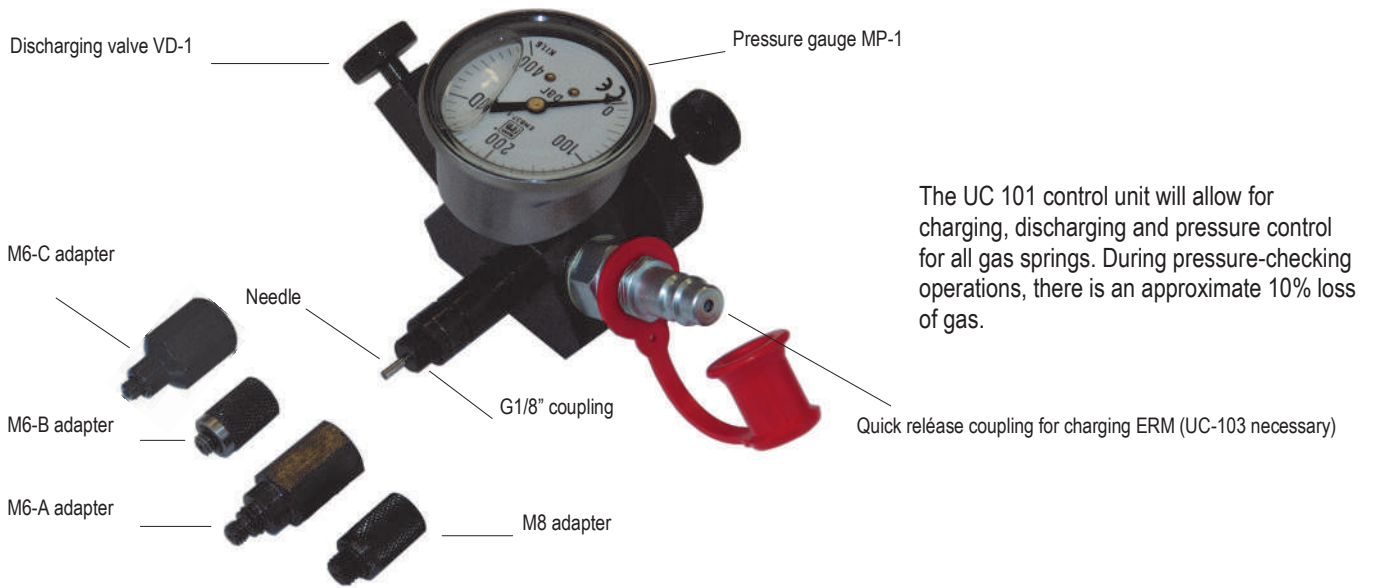

The UC 101 control unit will allow for charging, discharging and pressure control for all gas springs. During pressure-checking operations, there is an approximate 10% loss of gas.

MOUNTING INSTRUCTIONS

**For gas springs with a G1/8" thread**

- Step 1: unscrew the G1/8" spindle half-way until the needle is fully retracted.
- Step 2: screw the gas spring on to the G1/8" connector.

**For gas springs with a M6 or M8 thread**

- Step 1: screw an M6-A or M8 adaptor (as necessary) onto the G1/8" connector thread. If necessary, also screw in a M6-B or M6-C adaptor to the M6-A adaptor.
- Step 2: screw the gas spring in the charging tool on to the M6-A or M6-B or M6-C or M8 connector (as necessary).
- Step 3: plug the UC-103 charging hose into the quick release coupling.

**Charge to the recommended pressure in accordance with the safety instructions on page 4.**

UC-102 CHARGING UNIT FOR AUTONOMOUS GAS SPRINGS



The UC-102 charging unit is a charging device for autonomous gas springs. It is supplied with G1/8, M6A, M6-B, M6-C and M8 adaptors and charging couplings.

UC-103 CHARGING UNIT FOR CONTROL PANEL

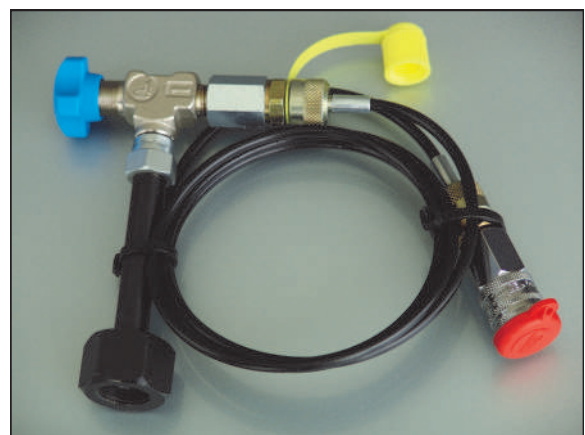

The UC-103 charging unit is a charging device for gas springs that are interconnected by means of a control panel.



INTERCONNECTED GAS SPRINGS EXAMPLES

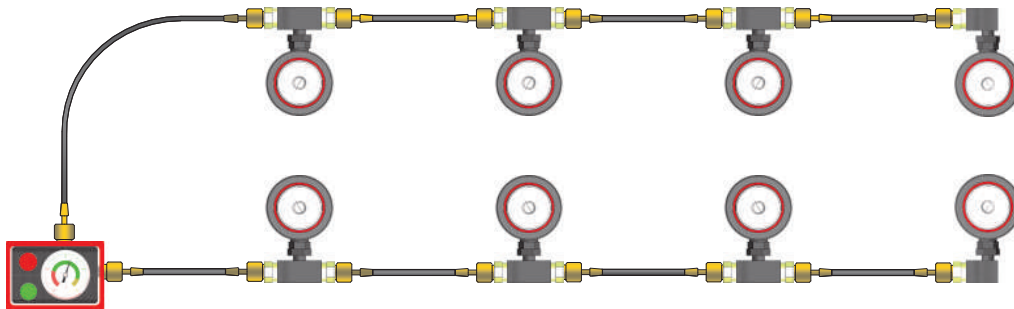
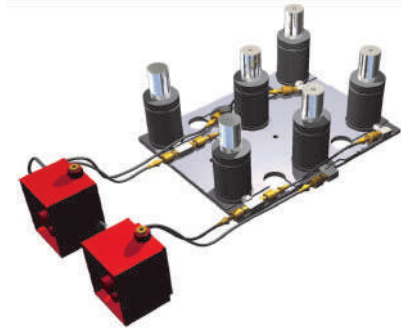
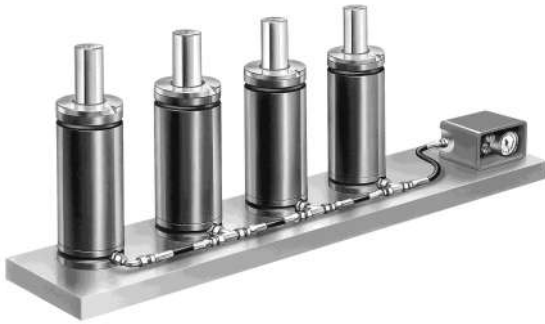

M6 STEM EXTRACTOR KEY  
EM6



M8 STEM EXTRACTOR KEY  
EM8

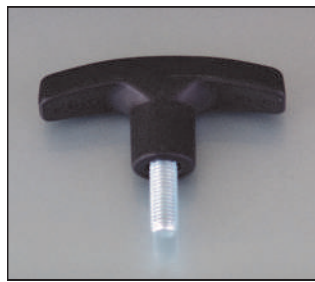

VALVE FITTING DEVICE  
DV-M6

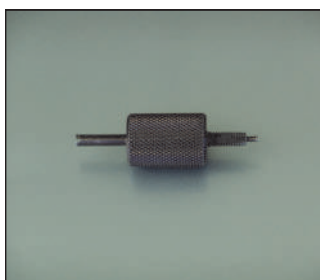

VALVE FITTING DEVICE  
DV-G1/8

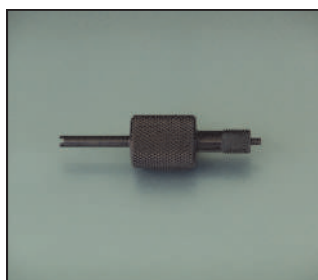

VALVE FITTING DEVICE  
DV-M6B





***The Innovator of Our Industry<sup>SM</sup>***

Our factories and offices:

U.S.A. • U.K. • France • Belgium • Germany • Sweden • Netherlands • Singapore • India

**DANLY UK LIMITED**  
(UK Sales Office)  
Maybrook House, Queensway  
Halesowen  
West Midlands  
B63 4AH

Tel: 0121 585 7171  
Fax: 0121 585 7272

**DANLY UK LIMITED**  
(Manufacturing Division)  
2 Aintree Road, Perivale  
Greenford  
Middlesex  
UB6 7LA

Tel: 0208 998 5381  
Fax: 0208 991 2461

E-mail: [sales@danlyuk.com](mailto:sales@danlyuk.com)  
Website: [www.danly.co.uk](http://www.danly.co.uk)

